

1		2		3		4		5		6	
Document No.	QR4-700-T-003	REV.	A/0	REV.	DESCRIPTION	REVISOR	DATE	APPROVED			
				0		ZC.Wu	12.30.2014	David			

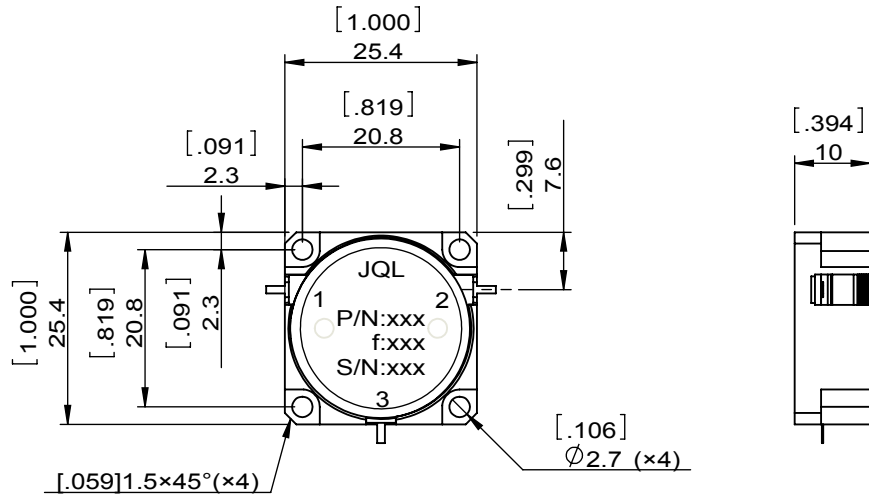
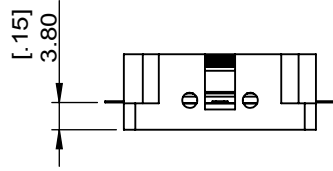
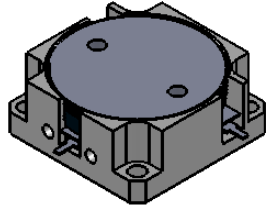

SPECIFICATIONS	
Part's Number	JCD1500T1700M10
Frequency(GHz)	1.500~1.700
Direction	CW
Insertion Loss(dB)MAX	0.35
Isolation(dB)MIN	20.0
Return Loss(dB)MIN	19.0
3rd IMD(dBc)MAX	-
Power FWD/REV/PK(Watt)	100/100/700
Operating Temperature(°C)	-40~85
Storage Temperature(°C)	-
2nd/3rd Harmonic(dBc)	-
Termination/Attenuator(Watt/dB)	-
Tab(W×LG×THK)(mm[Inch])	1.0[0.04]×2.5[0.10]×0.2[0.01]
Additional Notes	-

**NOTES:**

- 1.STANDARD INPUT/OUTPUT 50OHM IMPEDANCE
- 2.BEO FREE,LEAD FREE,NO Nd MATERIAL
- 3.RoHS COMPLIANT
- 4.S-PARAMETERS TO BE MEASURED BY CONECTING PORT 1 AND PORT 2 TO VNA, PORT 3 TO LOAD
- 5.LOAD RETURN LOSS IS 30dB OR HIGHER WHEN TUNING



This document is the property of JQL Electronic Inc. It cannot be copied, duplicated, used for manufacturing purposes or communicated to third party as a whole or partly, without the written consent of JQL Electronic Inc.

<b>JQL JQL Electronic Inc</b>				
<b>MATERIAL:</b> STEEL		<b>DWG NO:</b> JCD1500T1700M10		
<b>SURFACE TREATMENT:</b> NICKEL PLATING		DWG BY:	ZC.Wu	12.30.2014
<b>DESCRIPTION:</b> DROP-IN CIRCULATOR		CHK'D BY:		SCALE
		APPV'D BY:		1:1
Unit: mm[inch]		Tolerance: Liner: ±0.25 Anguar: ±0.5°	The First: 	
				A4