

1		2		3		4		5		6	
Document No.	QR4-700-T-003	REV.	A/0	REV.	DESCRIPTION	REVISOR	DATE	APPROVED			
		0		M.Hao	07.09.2013	David					

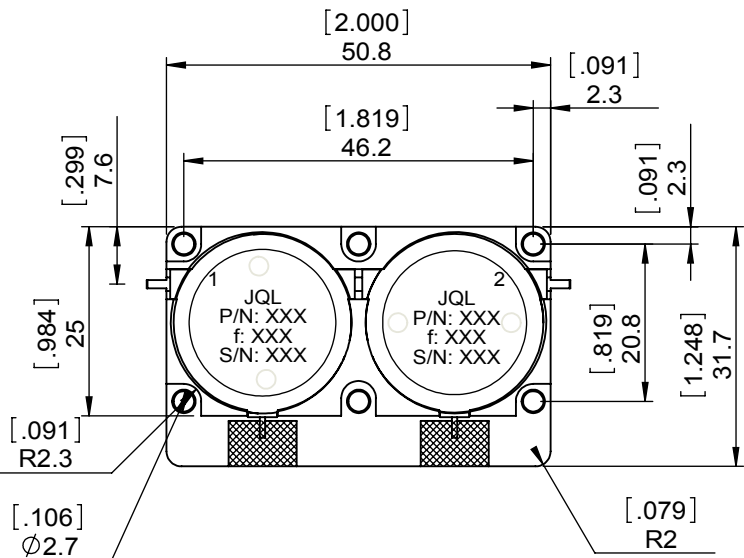
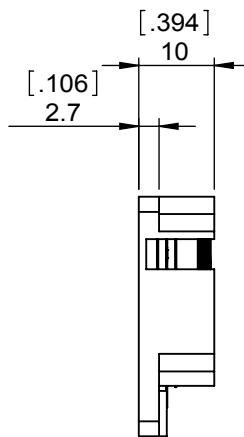
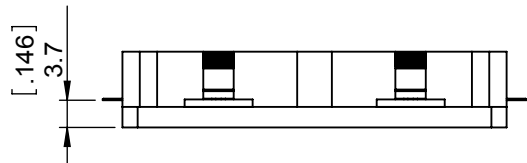
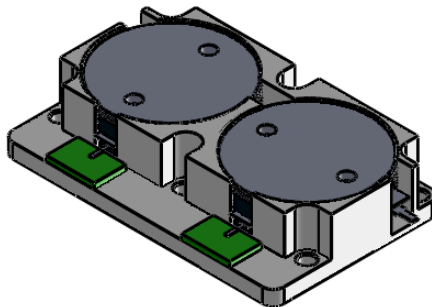

SPECIFICATIONS	
Part's Number	J12D0850T0875M10
Frequency(GHz)	0.850~0.875
Direction	CW
Insertion Loss(dB)MAX	0.5
Isolation(dB)MIN	46.0
Return Loss(dB)MIN	21
3rd IMD(dBc)MAX	-
Power FWD/REV/PK(Watt)	100/60/500
Operating Temperature(°C)	-20~+85
Storage Temperature(°C)	-
2nd/3rd Harmonic(dBc)	-
Termination/Attenuator(Watt/dB)	-
Tab(W×LG×THK)(mm[Inch])	1.1[.043]×2.5[.098]×0.2[.008]
Additional Notes	-

JQL JQL Electronic Inc 500 Lake Cook Road, Suite 350 Deerfield, IL 60015, USA Tel: 1(888)236-9828 Fax: 1(888)823-2902

MATERIAL: STEEL	DWG NO: J12D0850T0875M10			
SURFACE TREATMENT: NICKEL PLATING	DWG BY:	M.Hao	07.09.2013	SACLE
	CHK'D BY:			
DESCRIPTION DUAL JUNCTION DROP-IN ISOLATOR	APP'VD BY:			1:1
	Unit:	Tolerance:	The First:	A4
	mm[inch]	Liner: ±0.25 Anguar: ±0.5°		



This document is the property of JQL Electronic Inc. It cannot be copied, duplicated, used for manufacturing purposes or communicated to third party as a whole or partly, without the written consent of JQL Electronic Inc.