

| | | | | | | | | | | | |
|--------------|---------------|------|-----|-------|-------------|---------|------|----------|--|---|--|
| 1 | | 2 | | 3 | | 4 | | 5 | | 6 | |
| Document No. | QR4-700-T-003 | REV. | A/0 | REV. | DESCRIPTION | REVISOR | DATE | APPROVED | | | |
| | | 0 | | ZC.Wu | 03.02.2015 | David | | | | | |

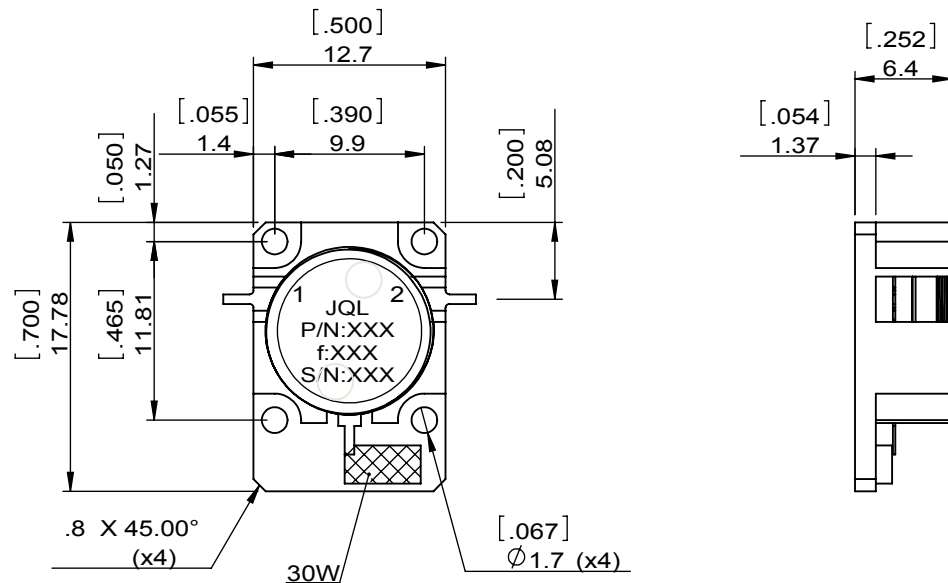

| SPECIFICATIONS | |
|---------------------------------|----------------------------------|
| Part's Number | JID4400T4900VM3 |
| Frequency(GHz) | 4.400~4.900 |
| Direction | CW |
| Insertion Loss(dB)MAX | 0.3 |
| Isolation(dB)MIN | 22.0 |
| Return Loss(dB)MIN | 20.0 |
| 3rd IMD(dBc)MAX | - |
| Power FWD/REV/PK(Watt) | 25/25/- |
| Operating Temperature(°C) | -40~+70 |
| Storage Temperature(°C) | - |
| 2nd/3rd Harmonic(dBc) | - |
| Termination/Attenuator(Watt/dB) | 30/- |
| Tab(W×LG×THK)(mm[Inch]) | 0.635[.030]X1.9[.070]X0.15[.010] |
| Additional Notes | - |

| | | | | |
|---|--|-----------------------------------|---|----------------|
| JQL JQL Electronic Inc | | | | |
| MATERIAL: STEEL | | DWG NO: JID4400T4900VM3 | | |
| SURFACE TREATMENT: NICKEL PLATING | | DWG BY: | ZC.Wu | 03.02.2015 |
| DESCRIPTION: DROP-IN ISOLATOR | | CHK'D BY: | | SCALE |
| | | APPV'D BY: | | 2:1 |
| | | Unit: mm[inch] | Tolerance: Liner: ±0.25 Anguar: ±0.5° | The First: |
| | | | | A4 |

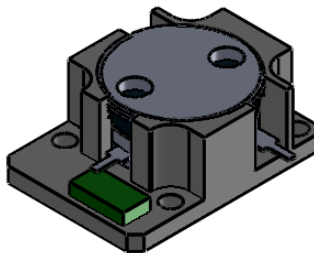
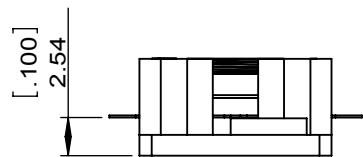

This document is the property of JQL Electronic Inc. It cannot be copied, duplicated, used for manufacturing purposes or communicated to third party as a whole or partly, without the written consent of JQL Electronic Inc.