

1

2

3

4

5

6

Stock Number

REV.	DESCRIPTION	REVISOR	DATE	APPROVE
0		MH	02.22.11	CH

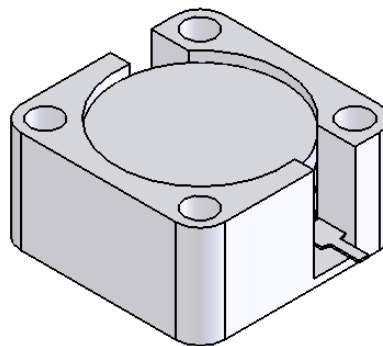

SPECIFICATION

Part's Number: JID5800T6700VM1
 Frequency: 5.80~6.70GHz
 Direction: CW
 Insertion Loss: 0.6dB MAX.
 Isolation: 17dB MIN.
 RL: 17dB MIN.
 Power : 1W
 Temperature: -30°C~+70°C

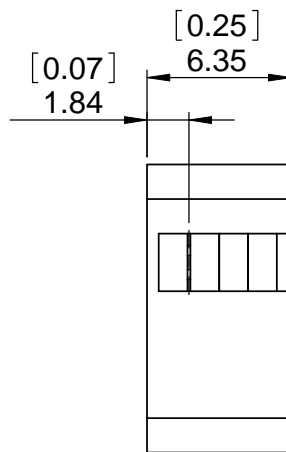
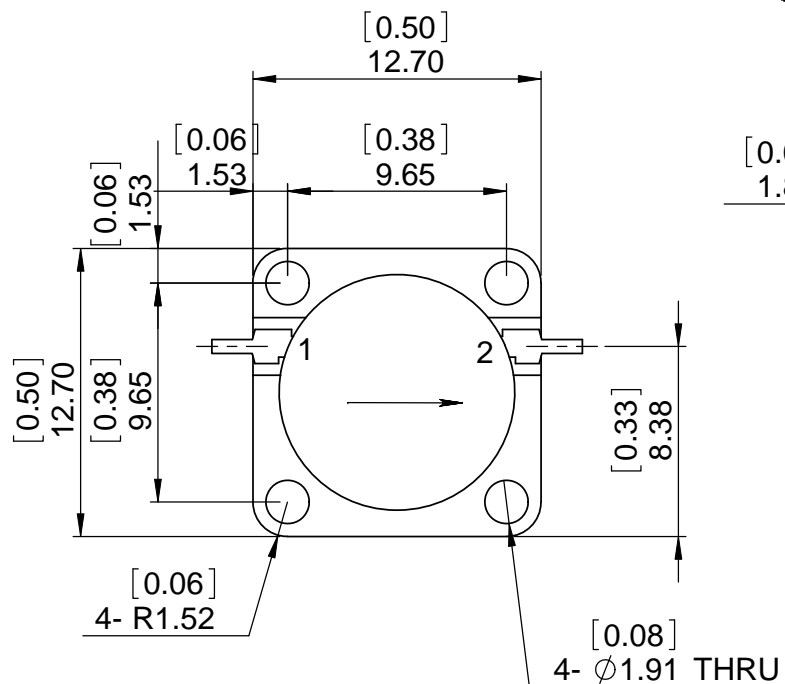

This document is the property of JQL Electronic Inc.
 It cannot be copied, duplicated, used for manufacturing purposes
 or communicated to third party as a whole or partly,
 without the written consent of JQL Electronic Inc.

JQL JQL Electronic Inc

500 Lake Cook Road, Suite 350 Tel : 1(888)236-9828
 Deerfield, IL 60015, USA Fax: 1(630)823-2902

MATERIAL: STEEL	DWG NO. JID5800T6700VM1		
SURFACE TREATMENT: NICKLE PLATING			
DESCRIPTION: DROP-IN ISOLATOR	NAME MH	DATE 02.22.11	SCALE: 1:1
	CHK'D BY: FW	02.22.11	1:1
	APPV'D BY: CH	02.22.11	
Unit: mm	TOLERANCE: Liner: ±0.1mm Angular: ±0.5°	Type Of Projection 	A4

1

2

WEIGHT:

SHEET 1 OF 1