

1		2		3		4		5		6	
Document No.	QR4-700-T-003					REV.	DESCRIPTION	REVISER	DATE	APPROVED	
REV.	A/0					0		ZQ.Hou	10.12.2015	David	

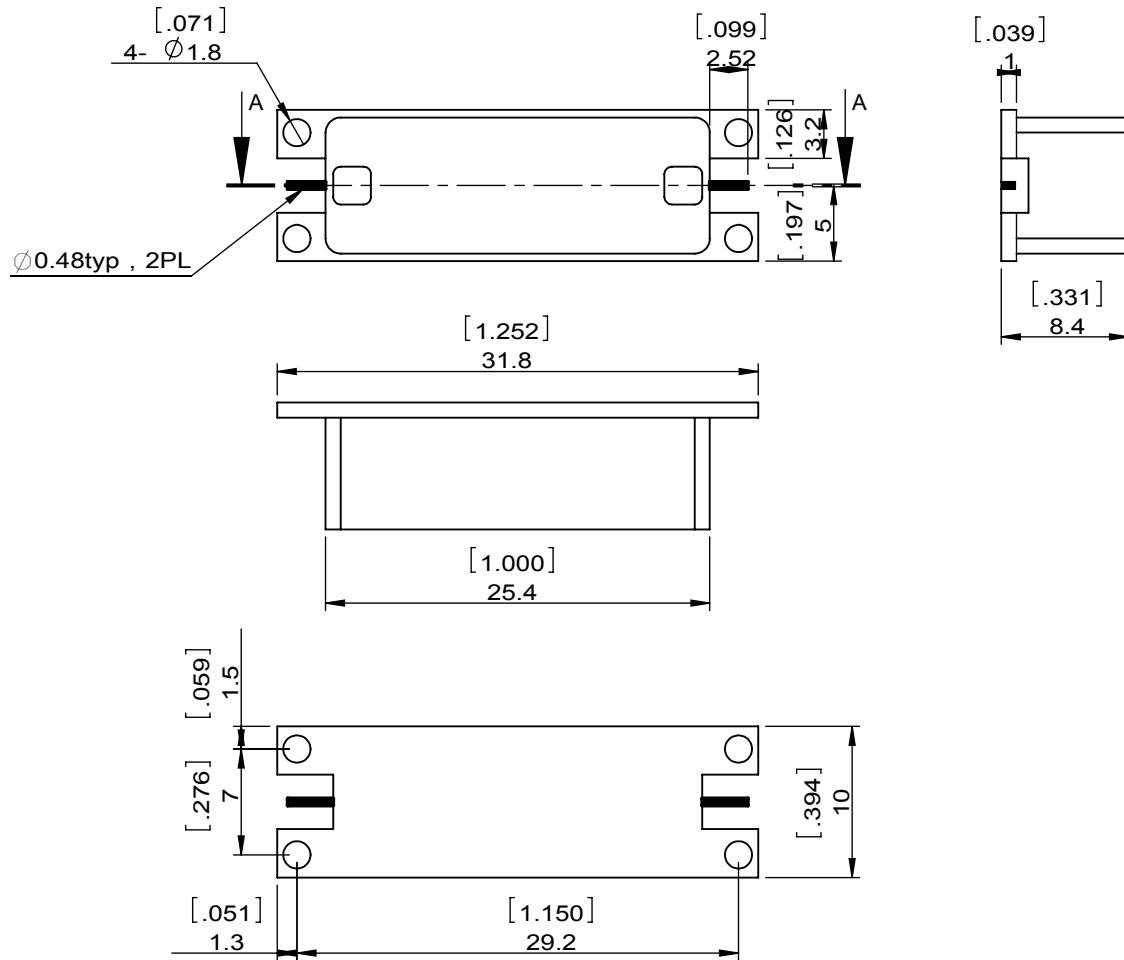

ITEM	SPECIFICATIONS
Center Frequency(MHz)	2155
Bandwidth(MHz)	2112.5~2197.5
Insertion Loss(dB)	2.0 Max
Ripple(dB)	1.0 Max
Reject(dB)	20 Min@2042.5&2267.5Mhz 40 Min@2347.5Mhz 50 Min@1962.5Mhz
Return Loss(dB)	14Min
Impedance(Ω)	50
Input Power(W)	2.0 Max
Temperature($^{\circ}$ C)	-40~+85
Notes	

TOLERANCE: ± 0.2
UNIT: mm
Connector : PIN



This document is the property of JQL Electronic Inc.
It cannot be copied, duplicated, used for manufacturing purposes
or communicated to third party as a whole or partly,
without the written consent of JQL Electronic Inc.

JQL JQL Electronic Inc				
MATERIAL:		DWG NO: JRP2155F8N85HA		
SURFACE TREATMENT:		DWG BY:	ZQ.Hou	10.12.2015
DESCRIPTION: FILTER		CHK'D BY:		SCALE
		APPV'D BY:		2:1
		Unit: mm[inch]	Tolerance: Liner: ± 0.25 Anguar: $\pm 0.5^{\circ}$	The First:
				A4