

1		2		3		4		5		6	
Document No.	QR4-700-T-003	REV.	A/0	REV.	DESCRIPTION	REVISOR	DATE	APPROVED			
				0		ZC.Wu	11.02.2016	David			

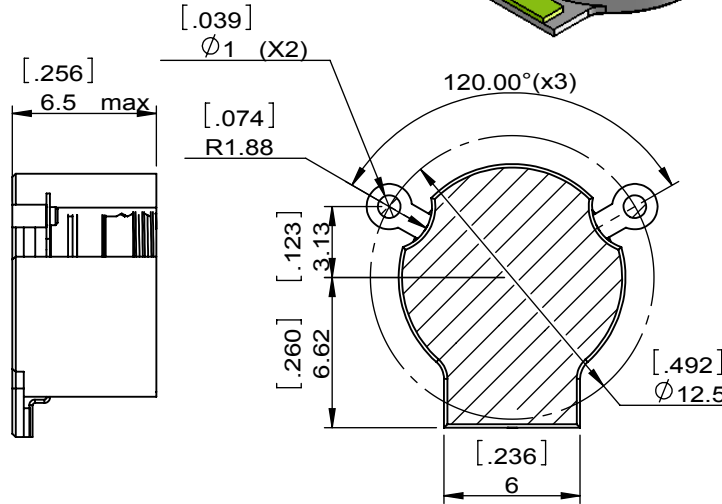

SPECIFICATIONS	
Part's Number	JIM1805T1880PT1
Frequency(GHz)	1.805~1.880
Direction	CW
Insertion Loss(dB)MAX	0.25
Isolation(dB)MIN	20.0
Return Loss(dB)MIN	20.0
3rd IMD(dBc)MAX	-65@2X10W
Power FWD/REV/PK(Watt)	10/10/-
Operating Temperature(°C)	-40~+125
Storage Temperature(°C)	
2nd/3rd Harmonic(dBc)	
Termination/Attenuator(Watt/dB)	15W
Tab(W×LG×THK)(mm[Inch])	-
Additional Notes	

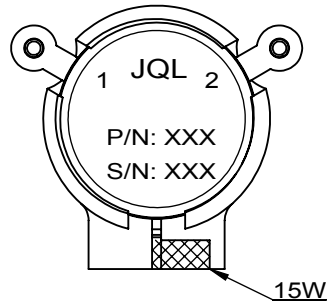
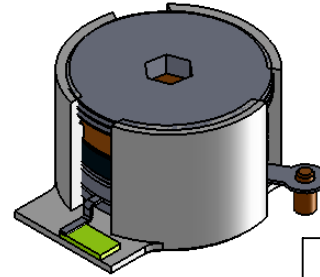
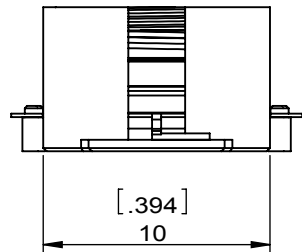
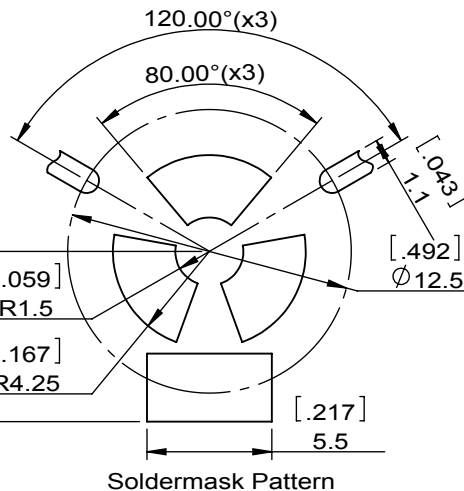
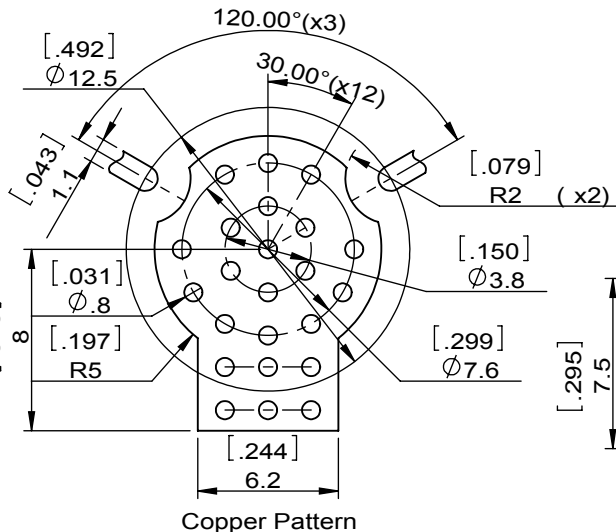

<b>JQL</b> JQL Electronic Inc				
<b>MATERIAL:</b> STEEL		<b>DWG NO:</b> JIM1805T1880PT1		
<b>SURFACE TREATMENT:</b> SILVER PLATING		DWG BY:	ZC.Wu	11.02.2016
<b>DESCRIPTION:</b> SMT ISOLATOR		CHK'D BY:		SCALE
		APPV'D BY:		3:1
		Unit: mm[inch]	Tolerance: Liner: ±0.25 Anguar: ±0.5°	The First: 
				A4



This document is the property of JQL Electronic Inc. It cannot be copied, duplicated, used for manufacturing purposes or communicated to third party as a whole or partly, without the written consent of JQL Electronic Inc.