

1		2		3		4		5		6	
Document No.	QR4-700-T-003	REV.	A/0	REV.	DESCRIPTION	REVISOR	DATE	APPROVED			
				0		Hu.Jiang	09.02.2019	HC.Qiu			

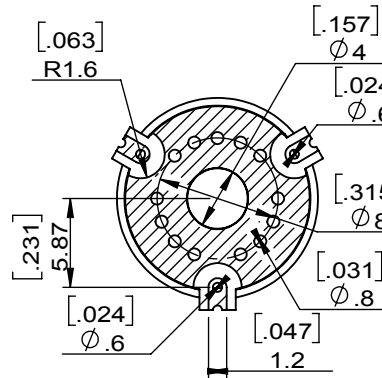

SPECIFICATIONS	
Part's Number	JCM5300T5900P60RC
Frequency(GHz)	5.300~5.900
Direction	CCW
Insertion Loss(dB)MAX	0.4
Isolation(dB)MIN	20.0
Return Loss(dB)MIN	20.0
3rd IMD(dBc)MAX	-
Power FWD/REV/PK(Watt)	-/-/600 Duty Cycle 20% (120W CW) 700uS Pulse
Operating Temperature(°C)	-40~+110
Storage Temperature(°C)	-
2nd/3rd Harmonic(dBc)	-
Termination/Attenuator(Watt/dB)	-
Tab(W×LG×THK)(mm[Inch])	
Additional Notes	-

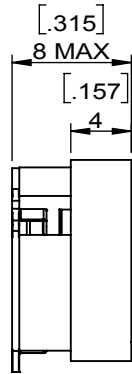
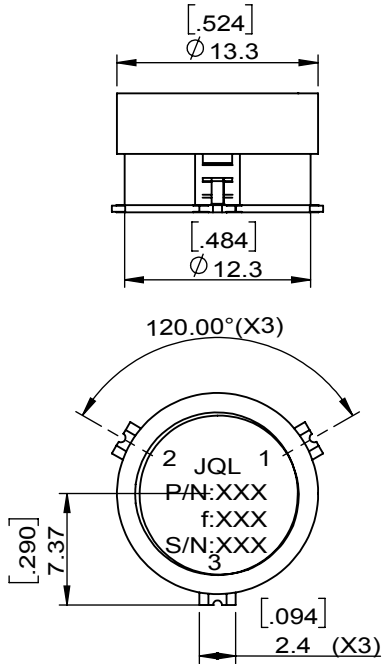
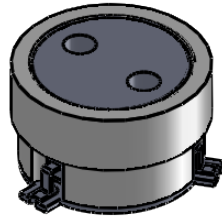
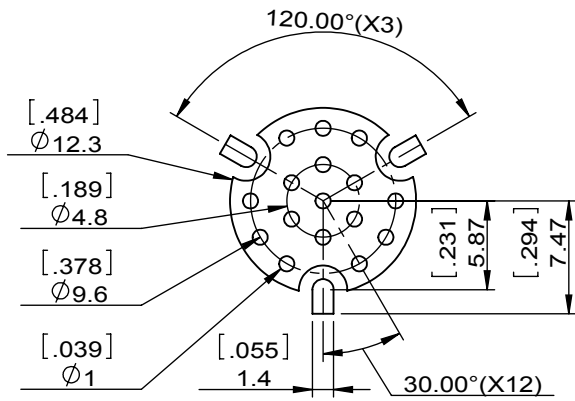

Copper Parttern

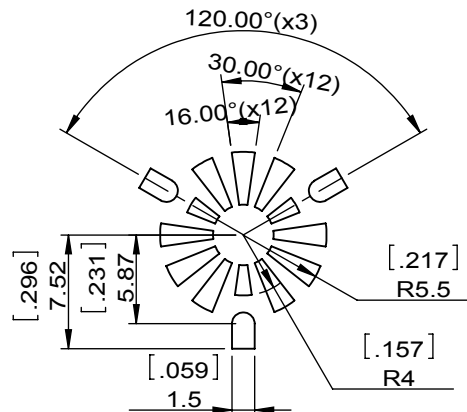

Soldermask Parttern

<b>JQL</b> JQL Electronic Inc				
<b>MATERIAL:</b> STEEL		<b>DWG NO:</b> JCM5300T5900P60RC		
<b>SURFACE TREATMENT:</b> SILVER PLATING		DWG BY:	Hu.Jiang	09.02.2019
<b>DESCRIPTION:</b> SMT-CIRCULATOR		CHK'D BY:		SCALE
		APPV'D BY:		2:1
		Unit: mm[inch]	Tolerance: Liner: ±0.25 Anguar: ±0.5°	The First: 
				A4



This document is the property of JQL Electronic Inc. It cannot be copied, duplicated, used for manufacturing purposes or communicated to third party as a whole or partly, without the written consent of JQL Electronic Inc.