

1		2		3		4		5		6			
Document No.	QR4-700-T-003	REV.	A/0	REV.	0	DESCRIPTION		REVISOR	LJ.Zhang	DATE	08.05.2014	APPROVED	David

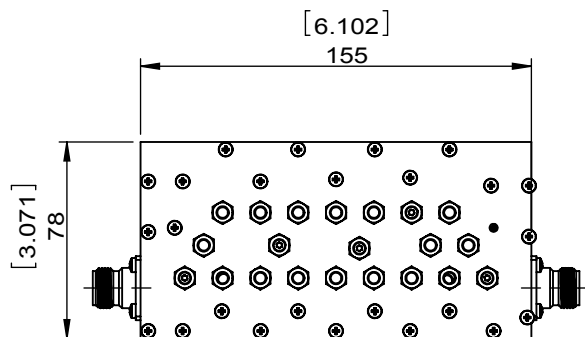
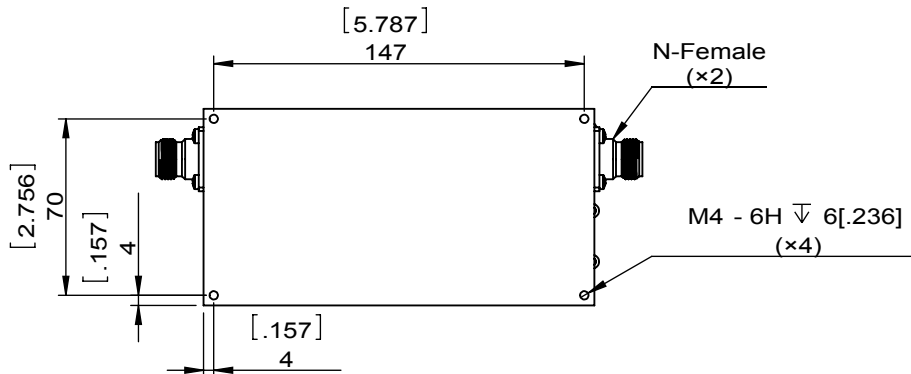

ITEM	SPECIFICATIONS
Frequency(MHz)	2025~2120
Insertion Loss(dB)	0.4 Max.
Return Loss(dB)	20 Min
Reject(dBc)	50 Min@1400~1850 MHz 50 Min@2200~2400 MHz
Filter Flatness(dB)	±0.1
Power Rating(Watt)	200 CW
Connector	N-Female
Impedance(Ω)	50 (in/out)
Operating Temperature(°C)	-50~+55
Additional Notes	-

JQL JQL Electronic Inc

MATERIAL:	DWG NO: JFCB2025T2120NF			
SURFACE TREATMENT: PAINTED BLACK	DWG BY:	LJ.Zhang	08.05.2014	SCALE
	CHK'D BY:			
DESCRIPTION: BANDPASS FILTER	APPV'D BY:			1:3
	Unit:	Tolerance:	The First:	A4
	mm[inch]	Liner: ±0.25 Anguar: ±0.5°		



This document is the property of JQL Electronic Inc. It cannot be copied, duplicated, used for manufacturing purposes or communicated to third party as a whole or partly, without the written consent of JQL Electronic Inc.