

1		2		3		4		5		6	
Document No.	QR4-700-T-003					REV.	DESCRIPTION	REVISOR	DATE	APPROVED	
REV.	A/0					0		LJ.Zhang	12.05.2013	David	

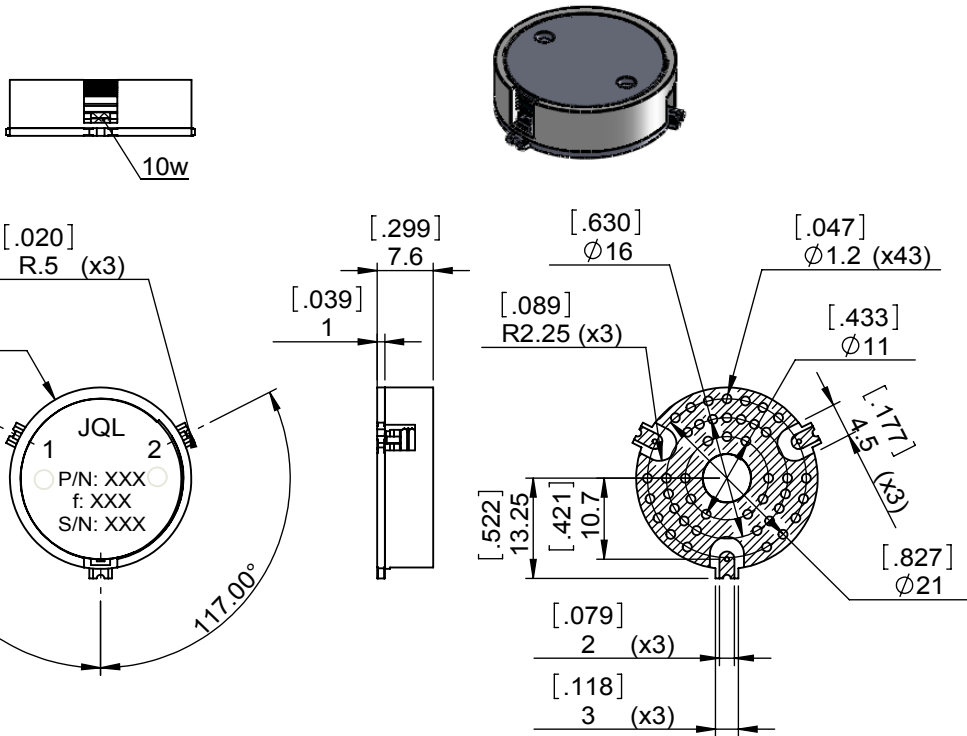

SPECIFICATIONS	
Part's Number	JIM1025T1035S0R
Frequency(GHz)	1.025~1.035
Direction	CW
Insertion Loss(dB)MAX	0.30
Isolation(dB)MIN	21.0
Return Loss(dB)MIN	21.0
3rd IMD(dBc)MAX	-
Power FWD/REV/PK(Watt)	5/5/-
Operating Temperature(°C)	-40~+85
Storage Temperature(°C)	
2nd/3rd Harmonic(dBc)	-
Termination/Attenuator(Watt/dB)	10(PORT3)
Tab(W×LG×THK)(mm[Inch])	-
Additional Notes	-

JQL JQL Electronic Inc 500 Lake Cook Road, Suite 350 Deerfield, IL 60015, USA Tel: 1(888)236-9828 Fax: 1(888)823-2902

MATERIAL: STEEL	DWG NO: JIM1025T1035S0R			
SURFACE TREATMENT: NICKEL PLATING	DWG BY:	LJ.Zhang	12.05.2013	SACLE
	CHK'D BY:			
DESCRIPTION: SMT ISOLATOR	APPV'D BY:			1:1
	Unit: mm[inch]	Tolerance: Liner: ±0.25 Anguar: ±0.5°	The First:	A4

RoHS COMPLIANCE This document is the property of JQL Electronic Inc. It cannot be copied, duplicated, used for manufacturing purposes or communicated to third party as a whole or partly, without the written consent of JQL Electronic Inc.