

1		2		3		4		5		6	
Document No.	QR4-700-T-003	REV.		REV.	DESCRIPTION	REVISOR	DATE	APPROVED			
REV.	A/0	0				ZQ.Hou	06.02.2015	David			

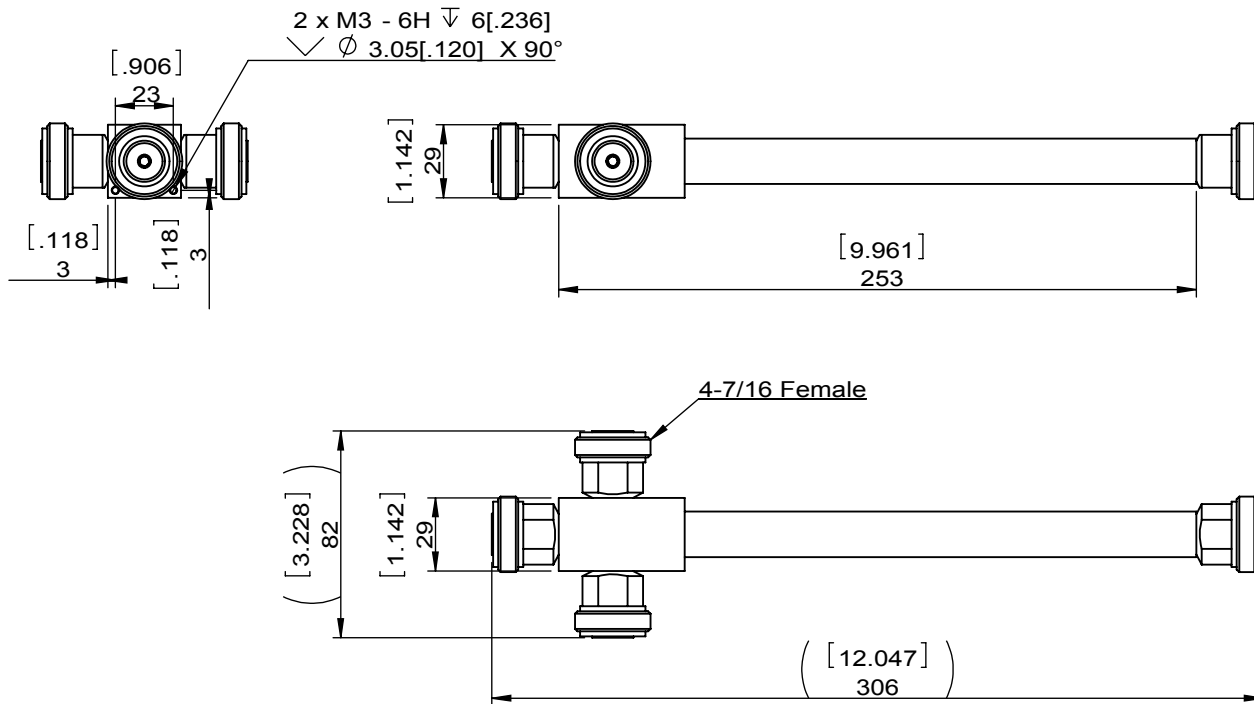

ITEM	SPECIFICATIONS
Frequency range(MHz)	698~2700
Insertion Loss(dB)	5.1 Max
Split Loss(dB)	4.8
Return Loss(dB)	18Min
Impedance( $\Omega$ )	50
Power Rating(W)	500W avg,3KW pk.
PIM(dBc)	160 Typ.155Min ( 2x43 dBm )
Environment	IP67,-35°C~+75°C RoHS compliant
Connector	7/16 FEMALE
Notes	

<b>JQL</b> JQL Electronic Inc				
<b>MATERIAL:</b>		<b>DWG NO:</b> PS0698T2700DF-3		
<b>SURFACE TREATMENT:</b> Passivated		DWG BY:	ZQ.Hou	06.02.2015
<b>DESCRIPTION:</b> 3 Way Power Splitters		CHK'D BY:		SCALE
		APPV'D BY:		1:3
Unit: mm[inch]	Tolerance: Liner: $\pm 0.25$ Anguar: $\pm 0.5^\circ$	The First:		A4



This document is the property of JQL Electronic Inc. It cannot be copied, duplicated, used for manufacturing purposes or communicated to third party as a whole or partly, without the written consent of JQL Electronic Inc.