

REV.	DESCRIPTION	REVISOR	DATE	APPROVE

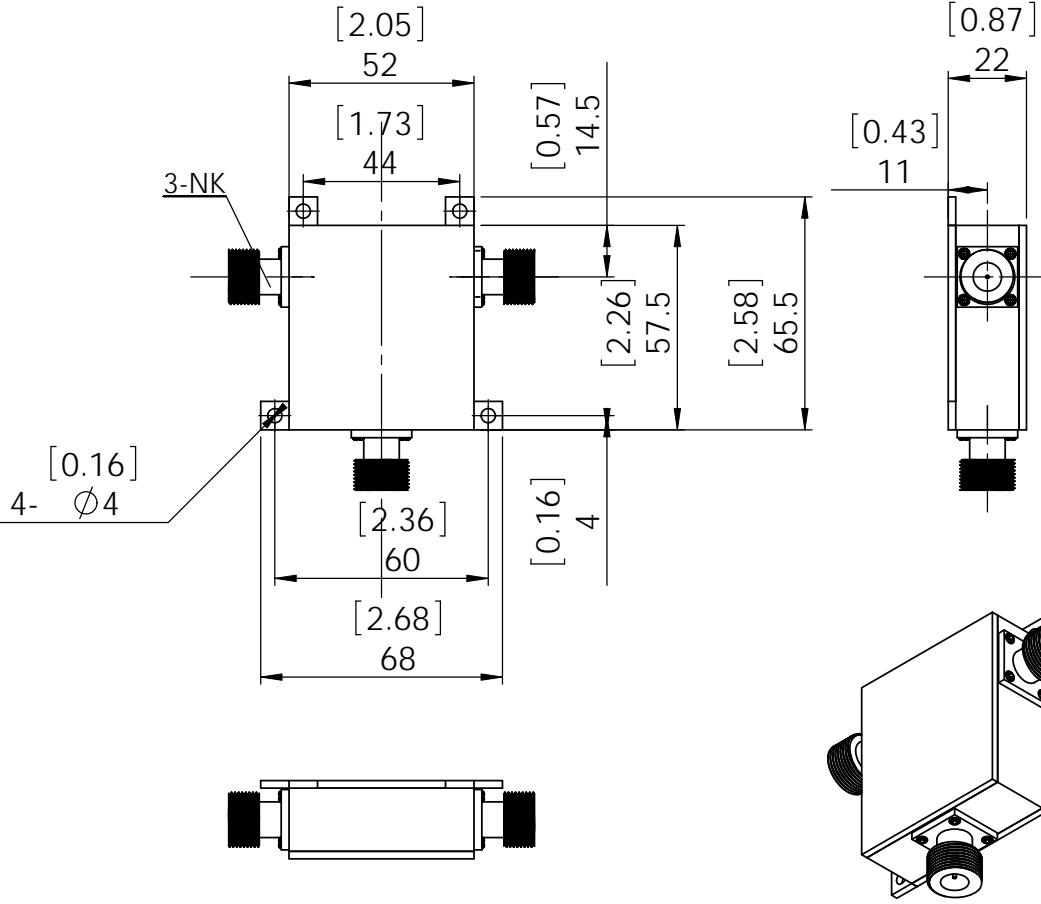

SPECIFICATIONS

P/N: JCC0410T0430N20
 FREQ: 0.410~0.430GHZ
 ISOLATION: 25dB MIN
 INS LOSS: 0.25dB MAX
 VSWR: 1.20:1 MAX
 POWER: 200W AVG
 CIRCULATION: CLOCKWISE
 CONNECTOR: N-FEMALE
 TEMPERATURE OPERATING: -20C~+60C
 STORAGE: -55C~+125C

This document is the property of JQL Electronic Inc. It cannot be copied, duplicated, used for manufacturing purposes or communicated to third party as a whole or partly, without the written consent of JQL Electronic Inc.

JQL JQL Electronic Inc 3501 Algonquin Road, Ste 230 Tel : 1(888)236-9828
 Rolling Meadows, IL 60008 Fax: 1(630)823-2902

MATERIAL: STEEL Y15	DWG NO. JCC0410T0430N20			
SURFACE TREATMENT: NICKLE PLATING	NAME	DATE	SIGNATURE	REV:
DESCRIPTION: COAX CIRCULATOR	DWG BY:			
	CHK'D BY:			
	APPV'D BY:			
	TOLERANCE Liner: ±0.1mm Angular: ±0.5°		Q.A	A4