

REV.	DESCRIPTION	REVISOR	DATE	APPROVE

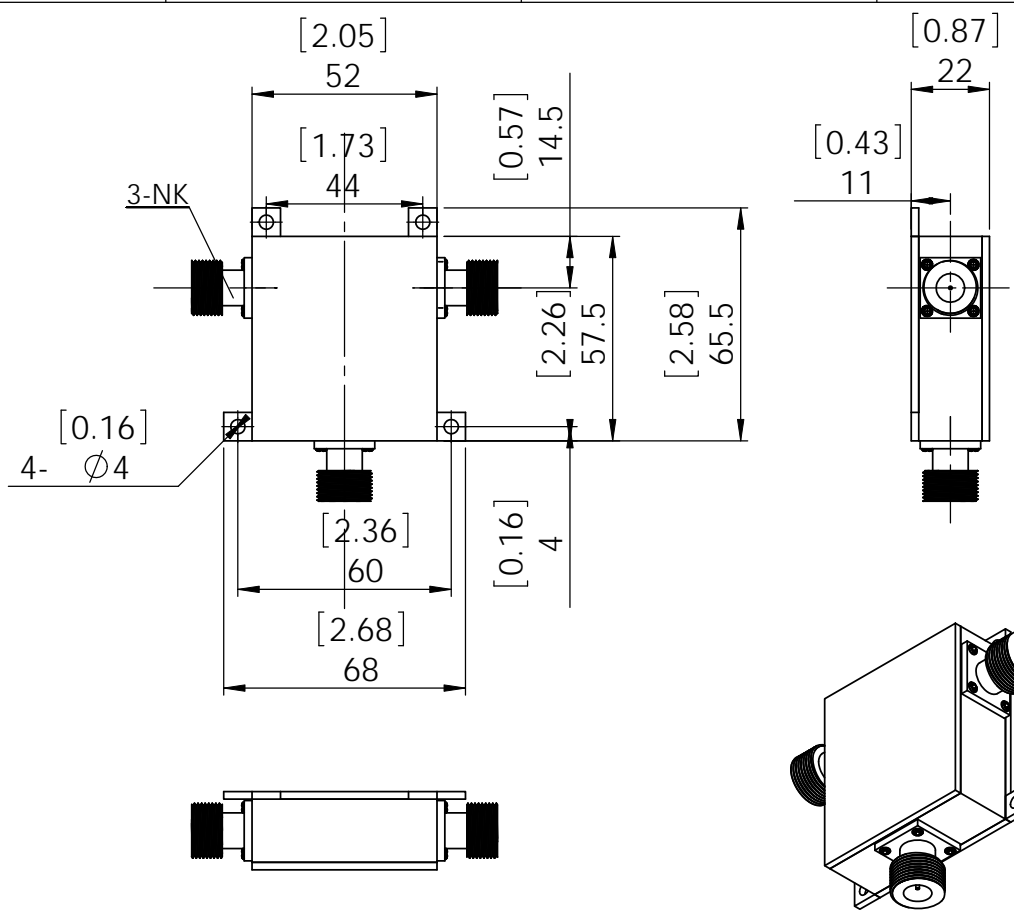

SPECIFICATIONS

P/N: JCC0467T0469N20
 FREQ: 0.467~0.469GHz

ISOLATION: 25dB MIN
 INS LOSS: 0.25dB MAX
 VSWR: 1.20:1 MAX
 POWER: 200W AVG
 CIRCULATION: CLOCKWISE
 CONNECTOR: N-FEMALE
 TEMPERATURE OPERATING: -20C~+80C
 STORAGE: -55C~+125C

CONNECTOR OPTION: N-F, N-M, SMA-F, SMA-M
 DRAWING SHOWS N-F BY DEFAULT, ACTUAL CONNECTOR CONFIGURATION REFERES TO SPECS.

This document is the property of JQL Electronic Inc. It cannot be copied, duplicated, used for manufacturing purposes or communicated to third party as a whole or partly, without the written consent of JQL Electronic Inc.

JQL JQL Electronic Inc		500 Lake Cook Road, Suite 350 Deerfield, IL 60015, USA		Tel : 1(888)236-9828 Fax: 1(630)823-2902	
MATERIAL: STEEL Y15		DWG NO. JCC0467T0469N20			
SURFACE TREATMENT: NICKLE PLATING		NAME		DATE	SIGNATURE
DESCRIPTION: COAX CIRCULATOR		DWG BY:			REV:
		CHK'D BY:			
		APPV'D BY:			
		TOLERANCE Liner: ±0.1mm Angular: ±0.5°		Q.A	A4