

1		2		3		4		5		6	
Document No.	QR4-700-T-003					REV.	DESCRIPTION	REVISOR	DATE	APPROVED	
REV.	A/0					0		ZC.Wu	08.26.2014	David	

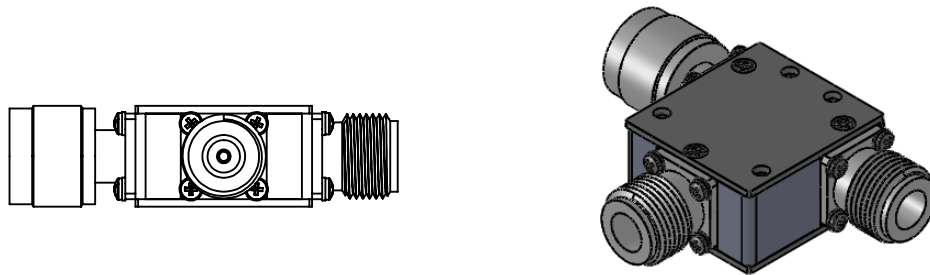

SPECIFICATIONS	
Part's Number	JCC0700T0850NMNFNF
Frequency(GHz)	0.700~0.850
Direction	-
Insertion Loss(dB)MAX	0.4
Isolation(dB)MIN	20.0
Return Loss(dB)MIN	19.0
3rd IMD(dBc)MAX	-
Power FWD/REV/PK(Watt)	100/100/-
Operating Temperature(°C)	0~+35
Storage Temperature(°C)	-
2nd/3rd Harmonic(dBc)	-
Termination/Attenuator(Watt/dB)	-
Tab(W×LG×THK)(mm[Inch])	-
Additional Notes	-

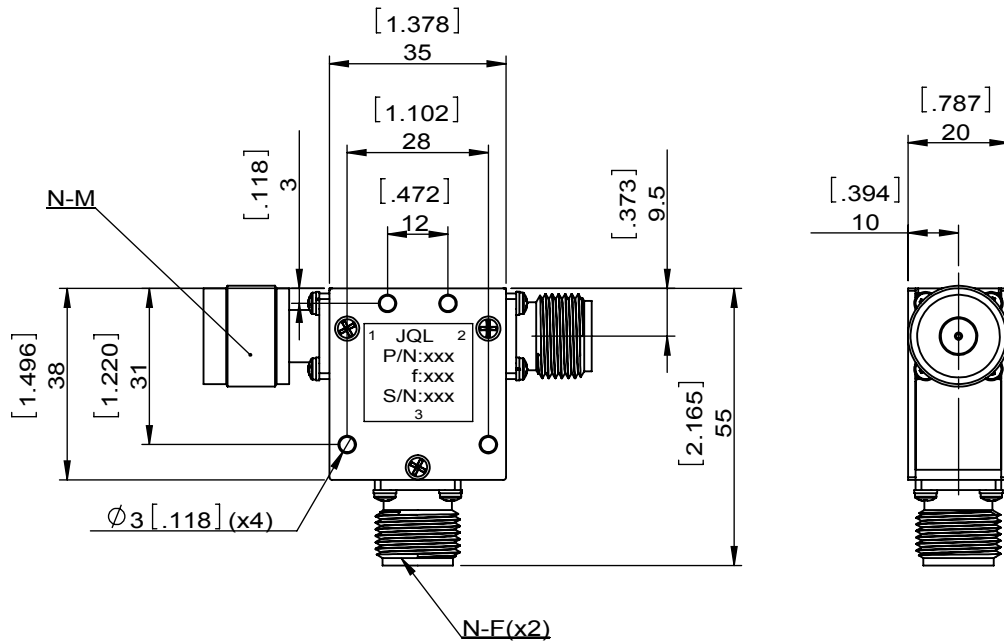

JQL JQL Electronic Inc				
MATERIAL: STEEL		DWG NO: JCC0700T0850NMNFNF		
SURFACE TREATMENT: NICKEL PLATING		DWG BY:	ZC.Wu	08.26.2014
DESCRIPTION: COAX CIRCULATOR		CHK'D BY:		SCALE
		APPV'D BY:		2:3
		Unit: mm[inch]	Tolerance: Liner: ±0.25 Anguar: ±0.5°	The First:
				A4



This document is the property of JQL Electronic Inc. It cannot be copied, duplicated, used for manufacturing purposes or communicated to third party as a whole or partly, without the written consent of JQL Electronic Inc.