

1

2

3

4

5

6

REV.	DESCRIPTION	REVISOR	DATE	APPROVE

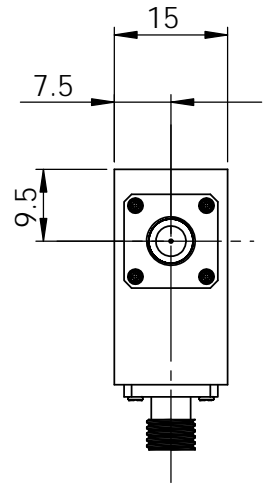
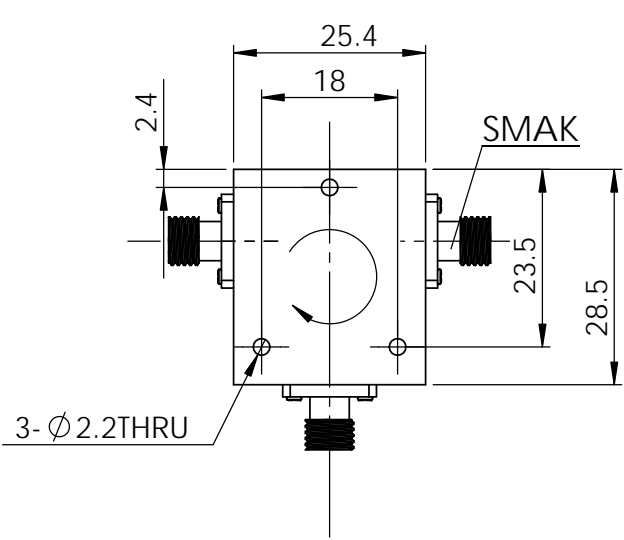

SPECIFICATIONS

P/N: JCC0800T0960S10
 FREQ: 0.8~0.96GHz
 ISOLATION: 20dB MIN
 INS LOSS: 0.4dB MAX
 VSWR: 1.25:1 MAX
 PWR: 100 W AVG
 TEMP: -30C~+70C
 CONNECTOR: SMA-F

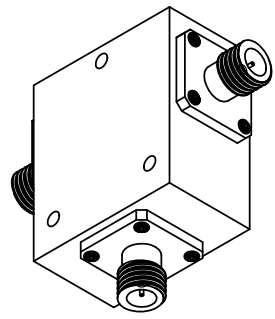
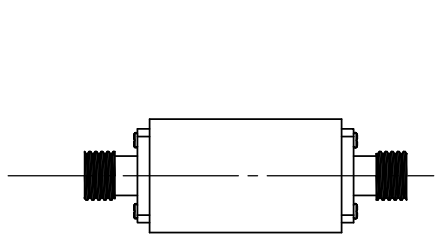

This document is the property of JQL Electronic Inc. It cannot be copied, duplicated, used for manufacturing purposes or communicated to third party as a whole or partly, without the written consent of JQL Electronic Inc.

JQL JQL Electronic Inc

MATERIAL:
VARIOUS

SURFACE TREATMENT:
NICKLE PLATING

DESCRIPTION:
COAX CIRCULATOR

DWG NO.		JCC0800T0960S10		
	NAME	DATE	SIGNATURE	REV
DWG BY:				
CHK'D BY:				
APPV'D BY:				
		TOLERANCE Liner: ±0.1mm Angular: ±0.5°	Q.A	A4

1

2

WEIGHT:

SCALE:1:1

SHEET 1 OF 1