

1	2
Document No.	QR4-700-T-003
REV.	A/0

4	5	6		
REV.	DESCRIPTION	REVISOR	DATE	APPROVED
0		M.Hao	09.17.2013	David

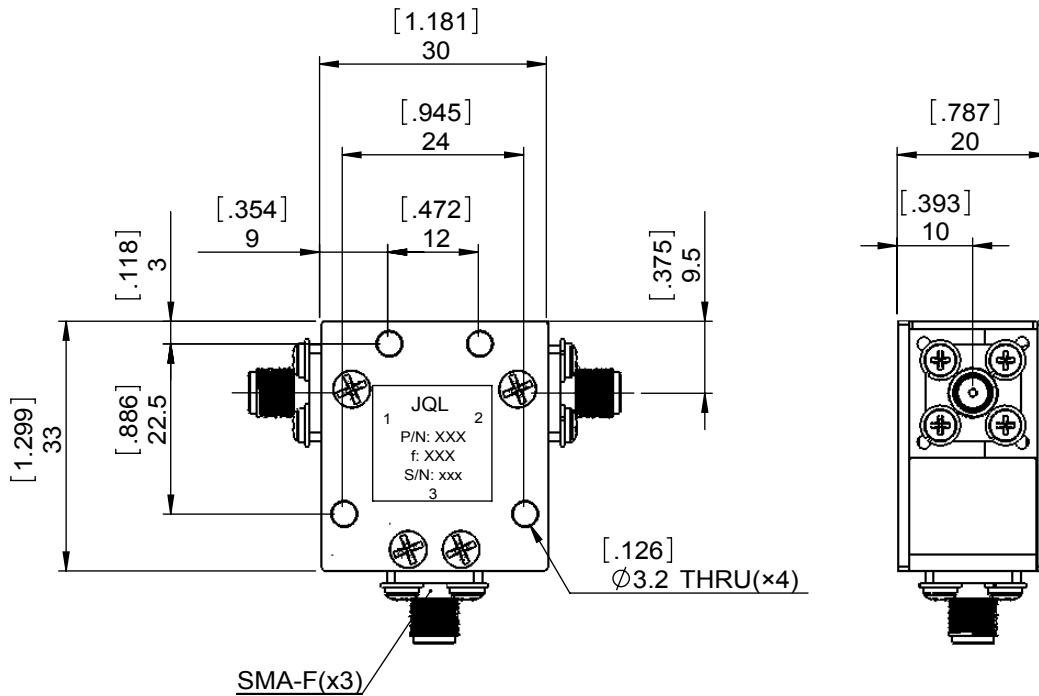
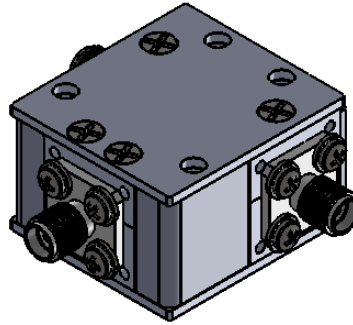
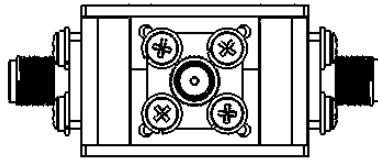

SPECIFICATIONS	
Part's Number	JCC0850T1100S10
Frequency(GHz)	0.850~1.100
Direction	-
Insertion Loss(dB)MAX	0.50
Isolation(dB)MIN	15.0
Return Loss(dB)MIN	17.0
3rd IMD(dBc)MAX	-
Power FWD/REV/PK(Watt)	10/10/-
Operating Temperature(°C)	-20~65
Storage Temperature(°C)	-
2nd/3rd Harmonic(dBc)	-
Termination/Attenuator(Watt/dB)	-
Tab(W×LG×THK)(mm[Inch])	-
Additional Notes	-

JQL JQL Electronic Inc				
MATERIAL: STEEL		DWG NO: JCC0850T1100S10		
SURFACE TREATMENT: NICKEL PLATING		DWG BY:	M.Hao	09.17.2013
DESCRIPTION: COAXIAL CIRCULATOR		CHK'D BY:		SACLE
		APPV'D BY:		1:1
		Unit: mm[inch]	Tolerance: Liner: ±0.25 Anguar: ±0.5°	The First:
				A4



This document is the property of JQL Electronic Inc. It cannot be copied, duplicated, used for manufacturing purposes or communicated to third party as a whole or partly, without the written consent of JQL Electronic Inc.