

1		2		3		4		5		6	
Document No.	QR4-700-T-003					REV.	DESCRIPTION	REVISOR	DATE	APPROVED	
REV.	A/0					0		ZC.W	03.23.2015	David	

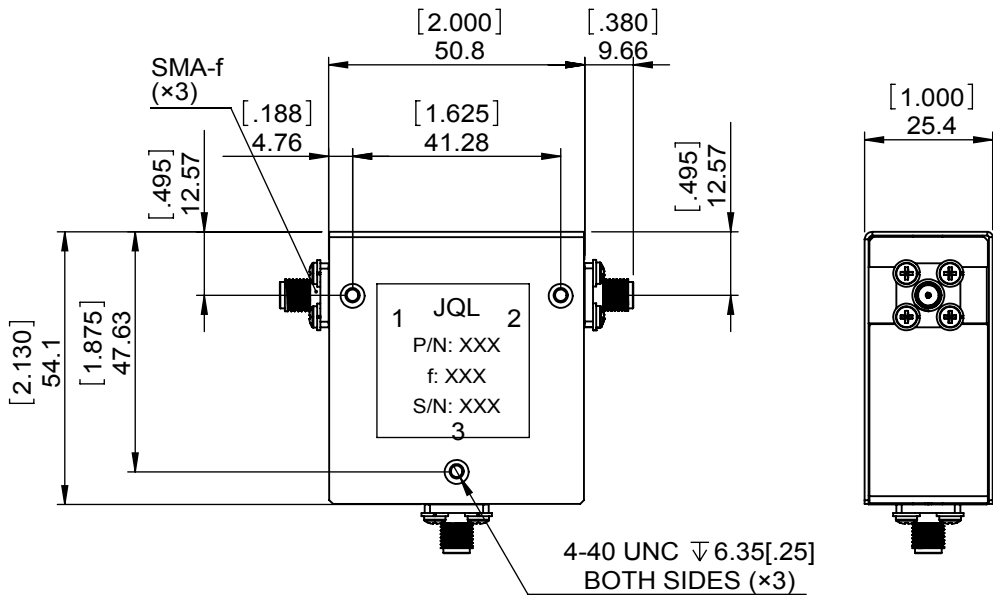

SPECIFICATIONS	
Part's Number	JCC1485T2130S10
Frequency(GHz)	1.485~2.130
Direction	-
Insertion Loss(dB)MAX	0.40
Isolation(dB)MIN	19.0
Return Loss(dB)MIN	19.0
3rd IMD(dBc)MAX	-
Power FWD/REV/PK(Watt)	100/100/-
Operating Temperature(°C)	-30~75
Storage Temperature(°C)	-
2nd/3rd Harmonic(dBc)	-
Termination/Attenuator(Watt/dB)	-
Tab(W×LG×THK)(mm[Inch])	-
Additional Notes	-

JQL JQL Electronic Inc				
MATERIAL: STEEL		DWG NO: JCC1485T2130S10		
SURFACE TREATMENT: NICKEL PLATING		DWG BY:	ZC.W	03.23.2015
DESCRIPTION: COAX CIRCULATOR		CHK'D BY:		SCALE
		APPV'D BY:		2:3
		Unit:	Tolerance:	The First:
		mm[inch]	Liner: ±0.25	
			Anguar: ±0.5°	A4

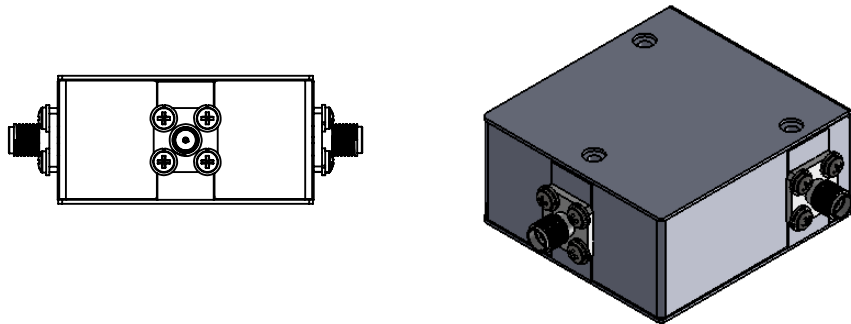

This document is the property of JQL Electronic Inc. It cannot be copied, duplicated, used for manufacturing purposes or communicated to third party as a whole or partly, without the written consent of JQL Electronic Inc.