

1		2		3		4		5		6	
Document No.	QR4-700-T-003	REV.	A/0	REV.	DESCRIPTION	REVISOR	DATE	APPROVED			
		0		ZC.Wu	06.11.2014	David					

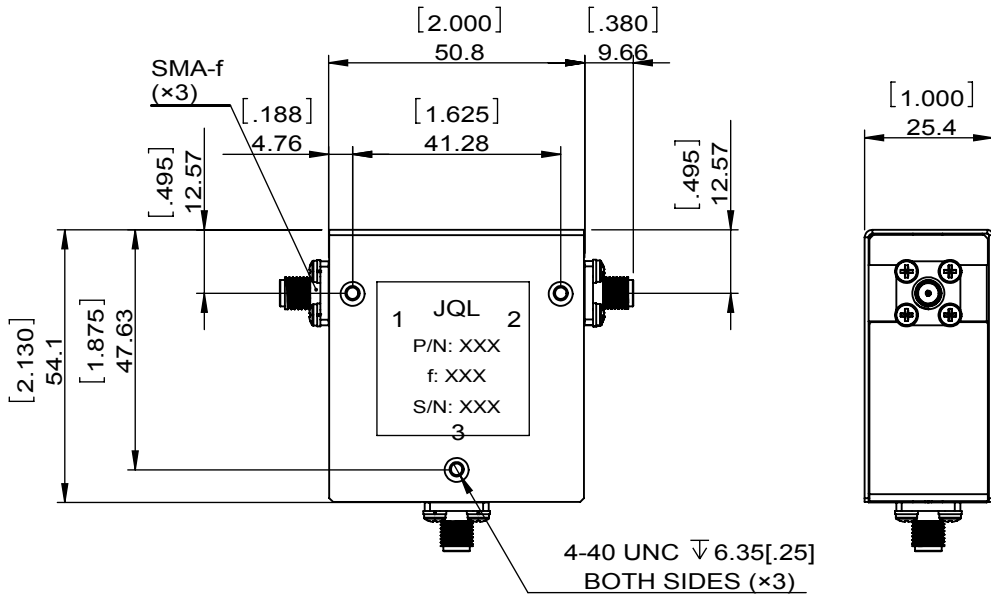

SPECIFICATIONS	
Part's Number	JCC1500T2500S2
Frequency(GHz)	1.500~2.500
Direction	-
Insertion Loss(dB)MAX	0.5
Isolation(dB)MIN	20.0
Return Loss(dB)MIN	20.0
3rd IMD(dBc)MAX	-
Power FWD/REV/PK(Watt)	30/30/300
Operating Temperature($^{\circ}$ C)	+10~65
Storage Temperature($^{\circ}$ C)	-
2nd/3rd Harmonic(dBc)	-
Termination/Attenuator(Watt/dB)	-
Tab(W \times LG \times THK)(mm[Inch])	-
Additional Notes	-

JQL JQL Electronic Inc				
MATERIAL: STEEL		DWG NO: JCC1500T2500S2		
SURFACE TREATMENT: NICKEL PLATING		DWG BY:	ZC.Wu	06.11.2014
DESCRIPTION: COAX CIRCULATOR		CHK'D BY:		SACLE
		APPV'D BY:		2:3
		Unit: mm[inch]	Tolerance: Liner: \pm 0.25 Anguar: \pm 0.5 $^{\circ}$	The First:
				A4

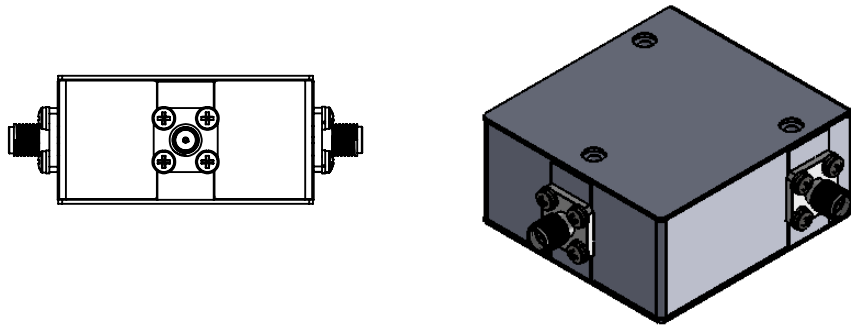

This document is the property of JQL Electronic Inc. It cannot be copied, duplicated, used for manufacturing purposes or communicated to third party as a whole or partly, without the written consent of JQL Electronic Inc.