

1		2		3		4		5		6	
Document No.		QR4-700-T-003		REV.		0		DESCRIPTION		APPROVED	
REV.		A/0						REVISOR		DATE	
								LJ.Zhang		03.20.2014	
										David	

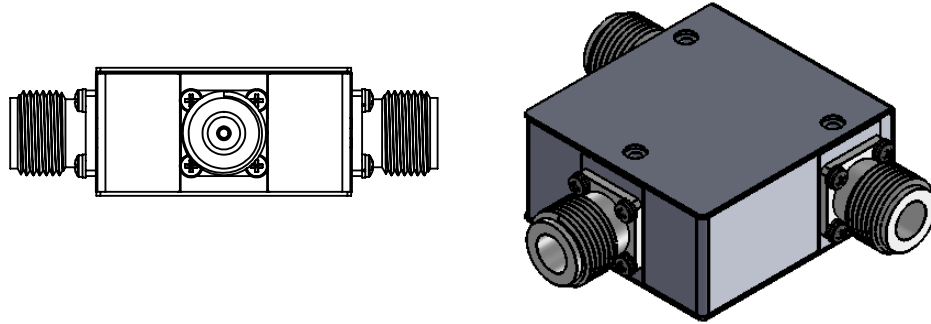

SPECIFICATIONS	
Part's Number	JCC1700T2500N10
Frequency(GHz)	1.700~2.500
Direction	-
Insertion Loss(dB)MAX	0.40
Isolation(dB)MIN	20.0
Return Loss(dB)MIN	20.0
3rd IMD(dBc)MAX	-
Power FWD/REV/PK(Watt)	100/100/-
Operating Temperature(°C)	-10~85
Storage Temperature(°C)	-
2nd/3rd Harmonic(dBc)	-
Termination/Attenuator(Watt/dB)	-
Tab(W×LG×THK)(mm[Inch])	-
Additional Notes	-

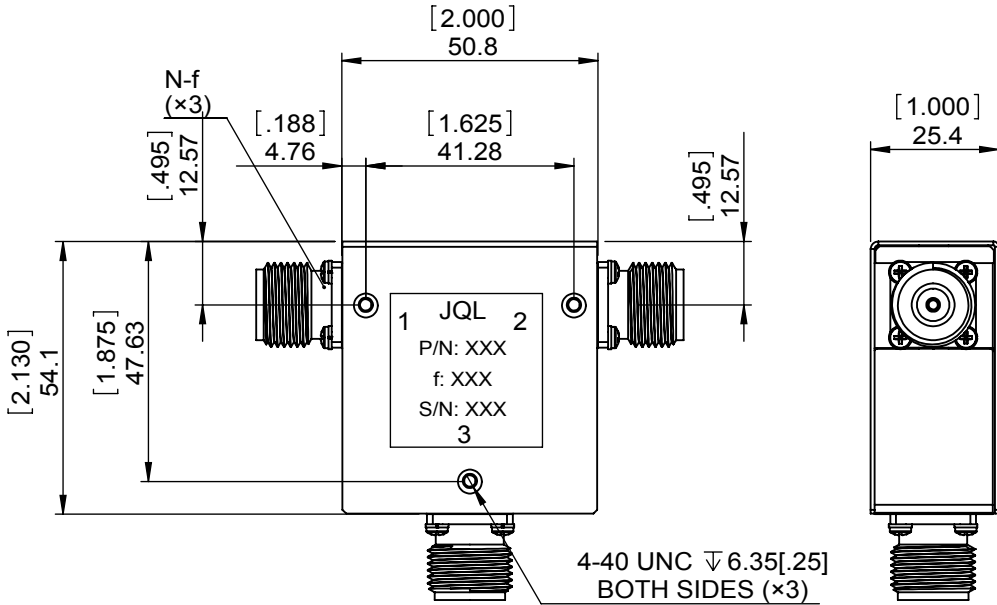

JQL JQL Electronic Inc				
MATERIAL: STEEL		DWG NO: JCC1700T2500N10		
SURFACE TREATMENT: NICKEL PLATING		DWG BY:	LJ.Zhang	03.20.2014
DESCRIPTION: COAX CIRCULATOR		CHK'D BY:		
		APPV'D BY:		
Unit:	Tolerance:	The First:		2:3
mm[inch]	Liner: ±0.25 Anguar: ±0.5°			
				A4



This document is the property of JQL Electronic Inc. It cannot be copied, duplicated, used for manufacturing purposes or communicated to third party as a whole or partly, without the written consent of JQL Electronic Inc.