

| | |
|--------------|---------------|
| 1 | 2 |
| Document No. | QR4-700-T-003 |
| REV. | A/0 |

| | | | | |
|------|-------------|---------|------------|----------|
| 4 | 5 | 6 | | |
| REV. | DESCRIPTION | REVISOR | DATE | APPROVED |
| 0 | | ZC.Wu | 05.30.2014 | David |

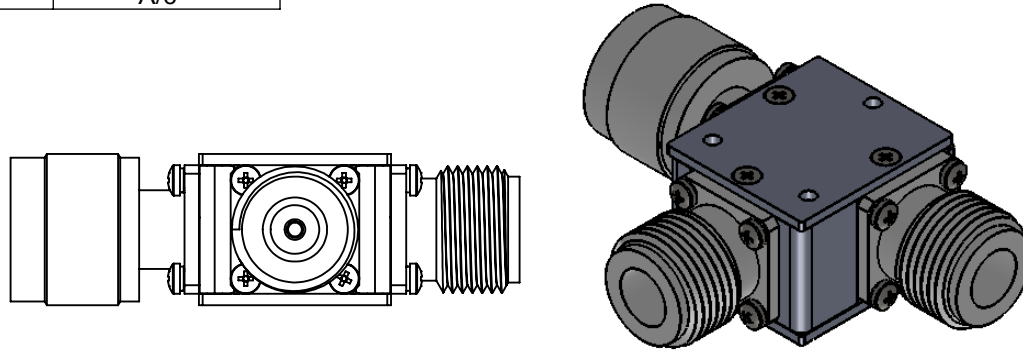

| SPECIFICATIONS | |
|---------------------------------|--|
| Part's Number | JCC2110T2170NMNFNF15 |
| Frequency(GHz) | 2.110~2.170 |
| Direction | - |
| Insertion Loss(dB)MAX | 0.25 |
| Isolation(dB)MIN | 22.0 |
| Return Loss(dB)MIN | 22.0 |
| 3rd IMD(dBc)MAX | |
| Power FWD/REV/PK(Watt) | 150/150/- |
| Operating Temperature(°C) | -20~+80 |
| Storage Temperature(°C) | - |
| 2nd/3rd Harmonic(dBc) | - |
| Termination/Attenuator(Watt/dB) | - |
| Tab(W×LG×THK)(mm[Inch]) | - |
| Additional Notes | Connector:Port1 N-M,Port2 N-F,Port3 N-F- |

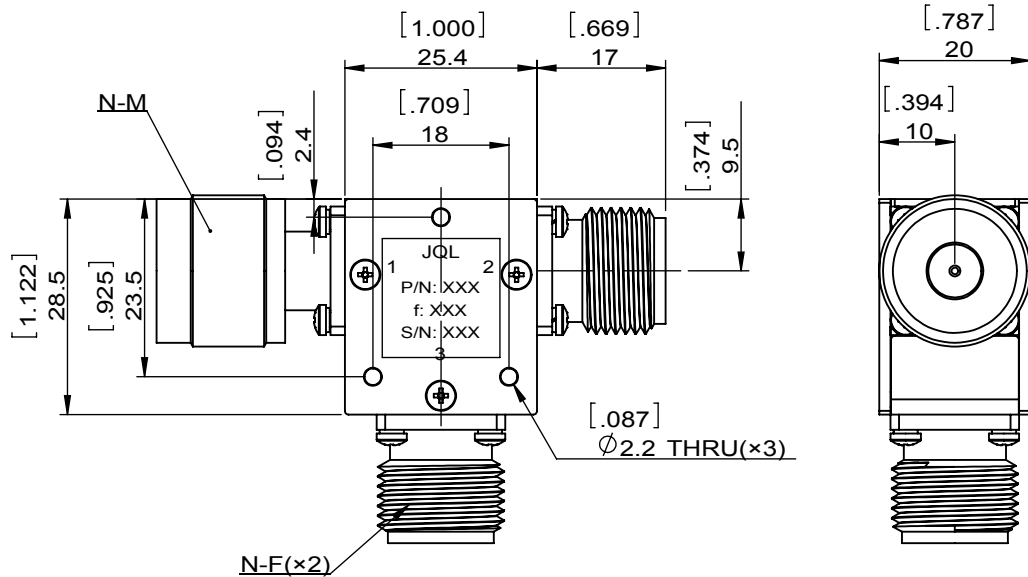

This document is the property of JQL Electronic Inc. It cannot be copied, duplicated, used for manufacturing purposes or communicated to third party as a whole or partly, without the written consent of JQL Electronic Inc.

| | | | | |
|---|---|--|-------|------------|
| JQL JQL Electronic Inc | | | | |
| MATERIAL: STEEL | | DWG NO: JCC2110T2170NMNFNF15 | | |
| SURFACE TREATMENT: NICKEL PLATING | | DWG BY: | ZC.Wu | 05.30.2014 |
| DESCRIPTION: COAXIAL CIRCULATOR | | CHK'D BY: | | SACLE |
| | | APPV'D BY: | | 1:1 |
| Unit: mm[inch] | Tolerance: Liner: ±0.25 Anguar: ±0.5° | The First: | | A4 |