

1		2		3		4		5		6	
Document No.	QR4-700-T-003	REV.	A/0	REV.	DESCRIPTION	REVISOR	DATE	APPROVED			
				0		ZC.Wu	09.25.2015	David			

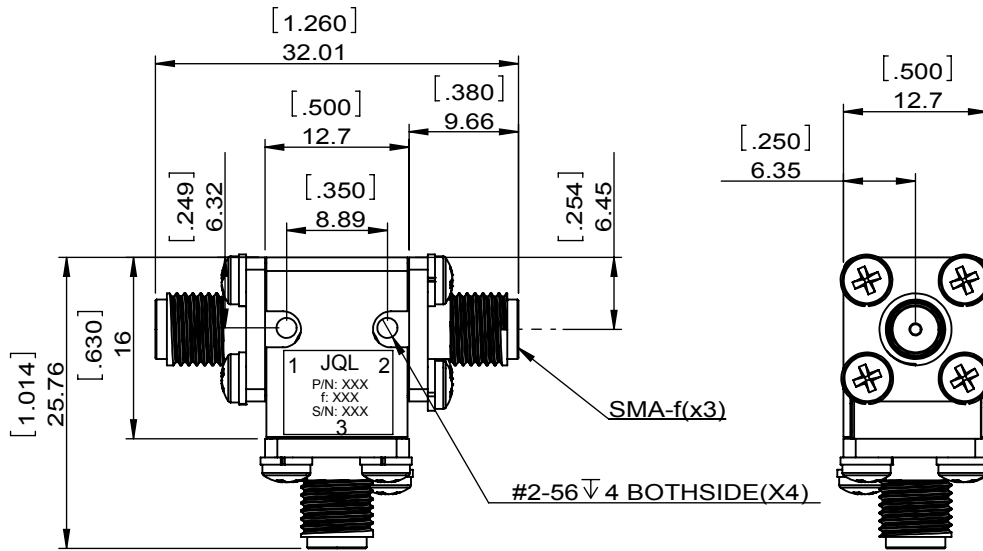

SPECIFICATIONS	
Part's Number	JCC6000T12K0S1D
Frequency(GHz)	6.000~12.000
Direction	CW
Insertion Loss(dB)MAX	0.6@25°C
Isolation(dB)MIN	16@25°C
Return Loss(dB)MIN	16@25°C
3rd IMD(dBc)MAX	-
Power FWD/REV/PK(Watt)	10/10/-
Operating Temperature(°C)	-30~+75
Storage Temperature(°C)	-
2nd/3rd Harmonic(dBc)	-
Termination/Attenuator(Watt/dB)	-
Tab(W×LG×THK)(mm[Inch])	-
Additional Notes	Connector: SMA-f-

JQL JQL Electronic Inc				
MATERIAL: STEEL		DWG NO: JCC6000T12K0S1D		
SURFACE TREATMENT: NICKEL PLATING		DWG BY:	ZC.Wu	09.25.2015
DESCRIPTION: COAXIAL CIRCULATOR		CHK'D BY:		SCALE
		APPV'D BY:		3:2
		Unit: mm[inch]	Tolerance: Liner: ±0.25 Anguar: ±0.5°	The First:
				A4

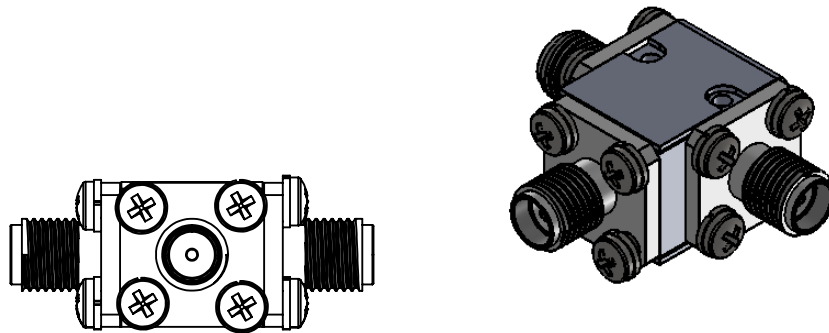

This document is the property of JQL Electronic Inc. It cannot be copied, duplicated, used for manufacturing purposes or communicated to third party as a whole or partly, without the written consent of JQL Electronic Inc.