

1		2		3		4		5		6	
Document No.	QR4-700-T-003	REV.	A/0	REV.	DESCRIPTION	REVISOR	DATE	APPROVED			
				0		ZC.Wu	07.21.2014	David			

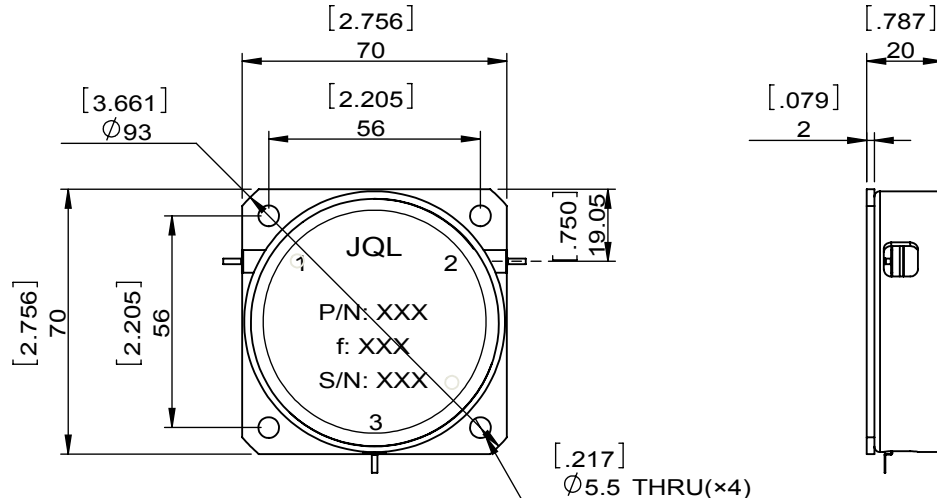
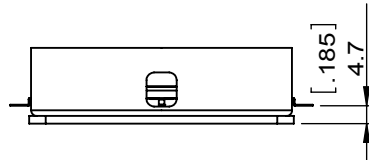
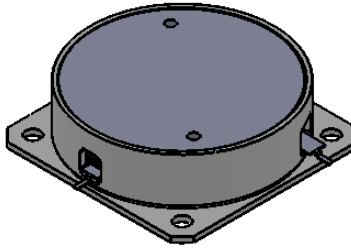

SPECIFICATIONS	
Part's Number	JCD0112T0156EM25
Frequency(GHz)	0.112~0.156
Direction	CW
Insertion Loss(dB)MAX	1(0.5 Target)
Isolation(dB)MIN	15
Return Loss(dB)MIN	15
3rd IMD(dBc)MAX	-
Power FWD/REV/PK(Watt)	80/80/250(16% duty cycle)
Operating Temperature(°C)	0~55
Storage Temperature(°C)	-
2nd/3rd Harmonic(dBc)	-
Termination/Attenuator(Watt/dB)	-
Tab(W×LG×THK)(mm[Inch])	1.5[.059]×5.0[.196]×0.25[.010]
Additional Notes	-

NOTES:

- 1.STANDARD INPUT/OUTPUT 50OHM IMPEDANCE
- 2.BEO FREE,LEAD FREE,NO Nd MATERIAL
- 3.RoHS COMPLIANT
- 4.S-PARAMETERS TO BE MEASURED BY CONECTING PORT 1 AND PORT 2 TO VNA, PORT 3 TO LOAD
- 5.LOAD RETURN LOSS IS 30dB OR HIGHER WHEN TUNING



This document is the property of JQL Electronic Inc. It cannot be copied, duplicated, used for manufacturing purposes or communicated to third party as a whole or partly, without the written consent of JQL Electronic Inc.

JQL JQL Electronic Inc				
MATERIAL: STEEL		DWG NO: JCD0112T0156EM25		
SURFACE TREATMENT: NICKEL PLATING		DWG BY:	ZC.Wu	07.21.2014
DESCRIPTION: DROP-IN CIRCULATOR		CHK'D BY:		SCALE
		APPV'D BY:		1:2
Unit: mm[inch]		Tolerance: Liner: ±0.25 Anguar: ±0.5°	The First: 	
				A4