

1		2		3		4		5		6	
Document No.	QR4-700-T-003					REV.	DESCRIPTION	REVISOR	DATE	APPROVED	
REV.	A/0					0		ZC.Wu	01.04.2015	David	

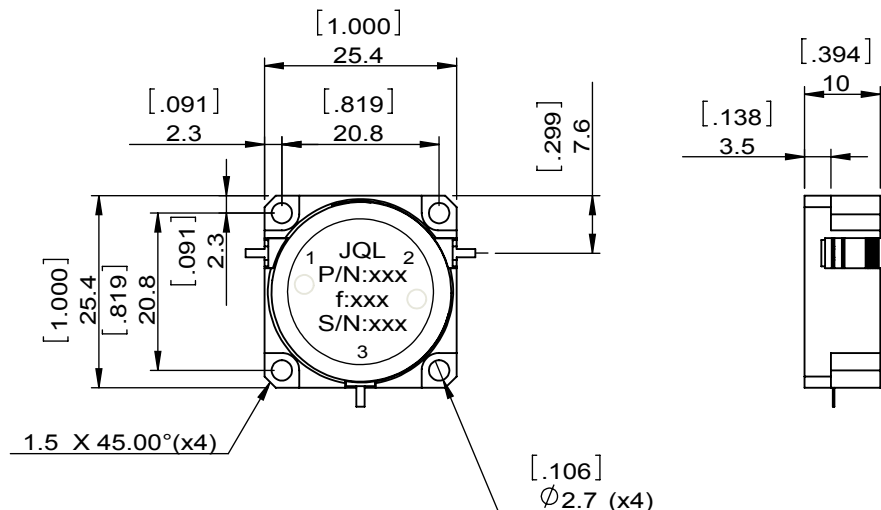

SPECIFICATIONS	
Part's Number	JCD0728T0768M10
Frequency(GHz)	0.728~0.768
Direction	CW
Insertion Loss(dB)MAX	0.30
Isolation(dB)MIN	20.0
Return Loss(dB)MIN	20.0
3rd IMD(dBc)MAX	-75 @ 2x35dBm 5MHz Spacing
Power FWD/REV/PK(Watt)	100/100/-
Operating Temperature(°C)	-20~+80
Storage Temperature(°C)	-
2nd/3rd Harmonic(dBc)	-
Termination/Attenuator(Watt/dB)	-
Tab(W×LG×THK)(mm[Inch])	1.0[0.039]×2.5[0.098]×0.2[0.008]
Additional Notes	-

- NOTES:  
 1.STANDARD INPUT/OUTPUT 50OHM IMPEDANCE  
 2.BEO FREE,LEAD FREE,NO Nd MATERIAL  
 3.RoHS COMPLIANT  
 4.S-PARAMETERS TO BE MEASURED BY CONECTING PORT 1 AND PORT 2 TO VNA, PORT 3 TO LOAD  
 5.LOAD RETURN LOSS IS 30dB OR HIGHER WHEN TUNING

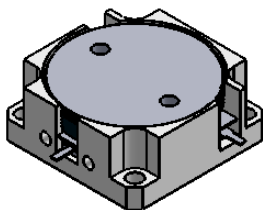
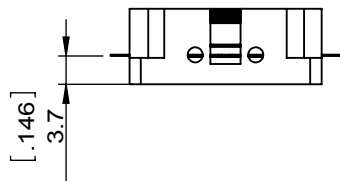

This document is the property of JQL Electronic Inc. It cannot be copied, duplicated, used for manufacturing purposes or communicated to third party as a whole or partly, without the written consent of JQL Electronic Inc.

<b>JQL JQL Electronic Inc</b>				
<b>MATERIAL:</b> STEEL		<b>DWG NO:</b> JCD0728T0768M10		
<b>SURFACE TREATMENT:</b> NICKEL PLATING		DWG BY:	ZC.Wu	01.04.2015
<b>DESCRIPTION:</b> DROP-IN CIRCULATOR		CHK'D BY:		SCALE
		APPV'D BY:		1:1
Unit: mm[inch]	Tolerance: Liner: ±0.25 Anguar: ±0.5°	The First:		A4