

1		2		3		4		5		6	
Document No.	QR4-700-T-003					REV.	DESCRIPTION	REVISOR	DATE	APPROVED	
REV.	A/0					0		LJ.Zhang	02.27.2014	David	

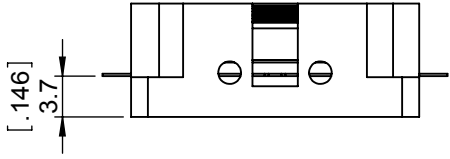

SPECIFICATIONS	
Part's Number	JCD0740T0760M6P
Frequency(GHz)	0.740~0.760
Direction	CW
Insertion Loss(dB)MAX	0.25
Isolation(dB)MIN	22.0
Return Loss(dB)MIN	22.0
3rd IMD(dBc)MAX	
Power FWD/REV/PK(Watt)	50/50/600 DC 0.4% 20ms
Operating Temperature(°C)	-40~+85
Storage Temperature(°C)	-
2nd/3rd Harmonic(dBc)	-
Termination/Attenuator(Watt/dB)	-
Tab(W×LG×THK)(mm[Inch])	1.0[0.039]×2.5[0.10]×0.2[0.008]
Additional Notes	-

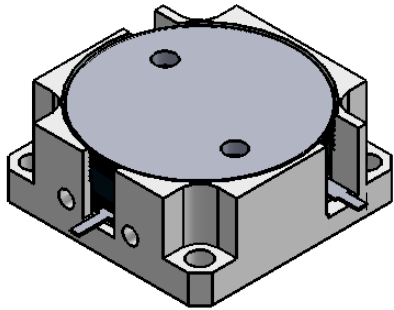
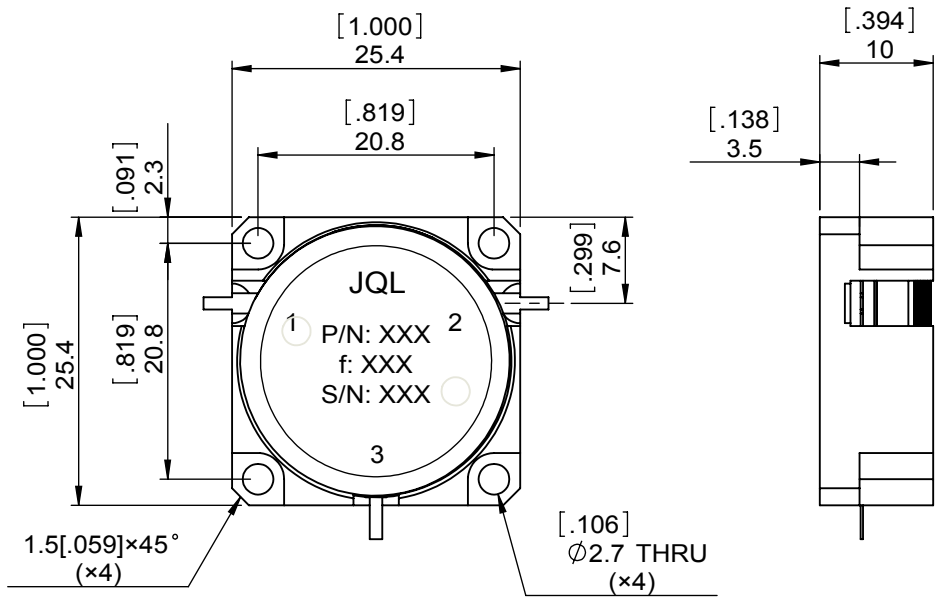

NOTES:  
 1.STANDARD INPUT/OUTPUT 50OHM IMPEDANCE  
 2.BEO FREE,LEAD FREE,NO Nd MATERIAL  
 3.RoHS COMPLIANT  
 4.S-PARAMETERS TO BE MEASURED BY CONECTING PORT 1 AND PORT 2 TO VNA, PORT 3 TO LOAD  
 5.LOAD RETURN LOSS IS 30dB OR HIGHER WHEN TUNING



This document is the property of JQL Electronic Inc. It cannot be copied, duplicated, used for manufacturing purposes or communicated to third party as a whole or partly, without the written consent of JQL Electronic Inc.

**JQL** JQL Electronic Inc 500 Lake Cook Road, Suite 350 Deerfield, IL 60015, USA Tel: 1(888)236-9828 Fax: 1(888)823-2902

<b>MATERIAL:</b> STEEL	<b>DWG NO:</b> JCD0740T0760M6P			
	DWG BY:	LJ.Zhang	02.27.2014	SACLE
<b>SURFACE TREATMENT:</b> NICKEL PLATING	CHK'D BY:			
	APPV'D BY:			3:2
<b>DESCRIPTION:</b> DROP-IN CIRCULATOR	Unit:	Tolerance:	The First:	A4
	mm[inch]	Liner: ±0.25 Anguar: ±0.5°		