

1		2		3		4		5		6	
Document No.	QR4-700-T-003	REV.	A/0	REV.	DESCRIPTION	REVISOR	DATE	APPROVED			
		0		ZC.Wu		03.09.2015		David			

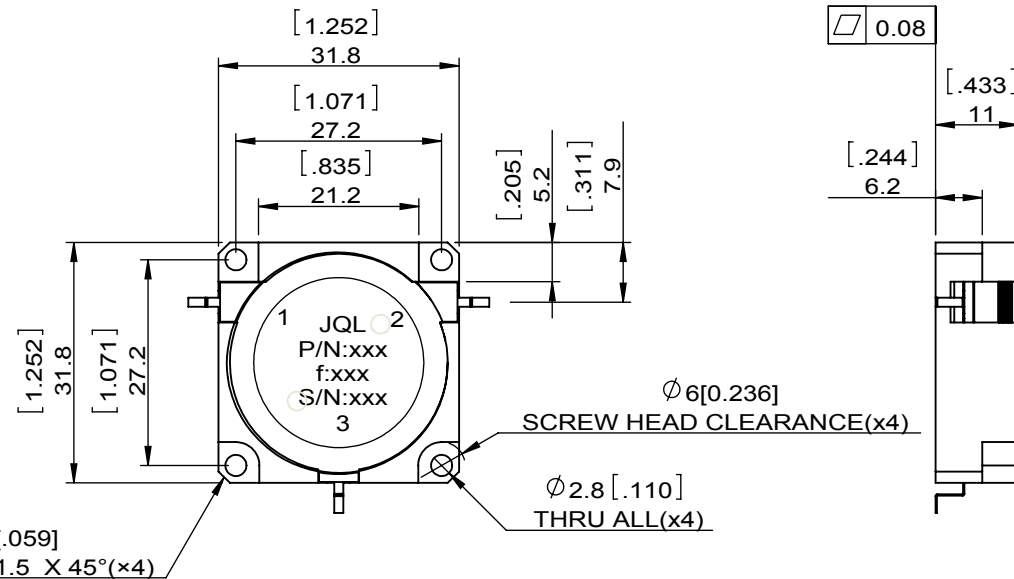
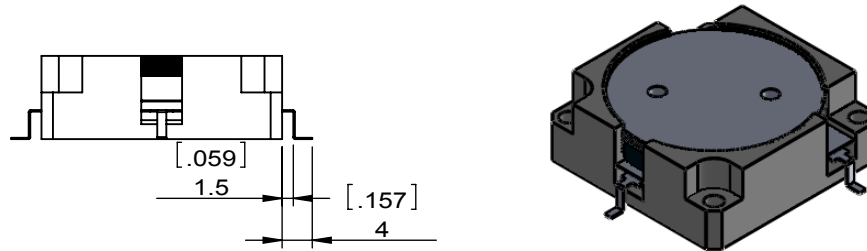

SPECIFICATIONS	
Part's Number	JCD0746T0960HM10
Frequency(GHz)	0.746~0.960
Direction	CW
Insertion Loss(dB)MAX	0.5
Isolation(dB)MIN	18.0
Return Loss(dB)MIN	18.0
3rd IMD(dBc)MAX	-67@2X30W,5MHz sparation
Power FWD/REV/PK(Watt)	100/100/500
Operating Temperature(°C)	-20~+85
Storage Temperature(°C)	-
2nd/3rd Harmonic(dBc)	-
Termination/Attenuator(Watt/dB)	-
Tab(W×LG×THK)(mm[Inch])	1.2[.047]x4.0[.157]x0.2[.008]
Additional Notes	PHASE MATCHING:±5°

NOTES:

- STANDARD INPUT/OUTPUT 50OHM IMPEDANCE
- BE0 FREE,LEAD FREE,NO Nd MATERIAL
- RoHS COMPLIANT
- S-PARAMETERS TO BE MEASURED BY CONECTING PORT 1 AND PORT 2 TO VNA, PORT 3 TO LOAD
- LOAD RETURN LOSS IS 30dB OR HIGHER WHEN TUNING



This document is the property of JQL Electronic Inc. It cannot be copied, duplicated, used for manufacturing purposes or communicated to third party as a whole or partly, without the written consent of JQL Electronic Inc.

JQL JQL Electronic Inc				
MATERIAL: STEEL		DWG NO: JCD0746T0960HM10C		
SURFACE TREATMENT: SILVER PLATING		DWG BY:	ZC.Wu	03.09.2015
DESCRIPTION: DROP-IN CIRCULATOR		CHK'D BY:		SCALE
		APPV'D BY:		1:1
Unit: mm[inch]		Tolerance: Liner: ±0.25 Anguar: ±0.5°	The First:	
				A4