

1		2		3		4		5		6	
Document No.	QR4-700-T-003	REV.	A/0	REV.	DESCRIPTION	REVISOR	DATE	APPROVED			
		0		ZC.Wu	08.26.2014	David					

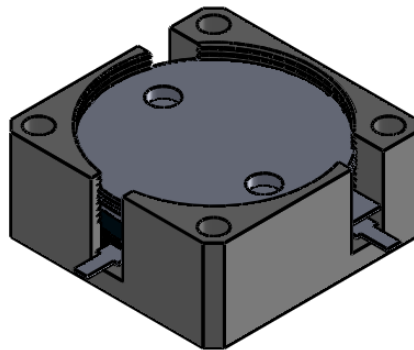

SPECIFICATIONS	
Part's Number	JCD0860T0960YM10
Frequency(GHz)	0.860~0.960
Direction	CW
Insertion Loss(dB)MAX	0.30
Isolation(dB)MIN	25.0
Return Loss(dB)MIN	25.0
3rd IMD(dBc)MAX	-75
Power FWD/REV/PK(Watt)	150/100/-
Operating Temperature(°C)	-20~+80
Storage Temperature(°C)	-
2nd/3rd Harmonic(dBc)	-
Termination/Attenuator(Watt/dB)	
Tab(W×LG×THK)(mm[Inch])	1.2[0.047]x2.5[0.098]x0.2[0.008]-
Additional Notes	-

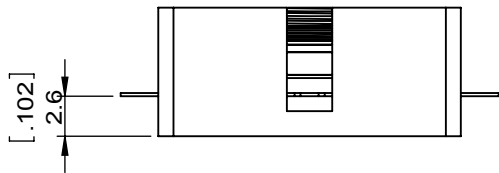
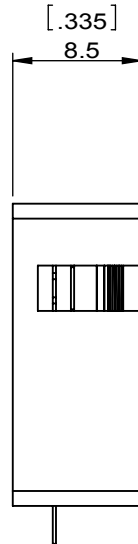
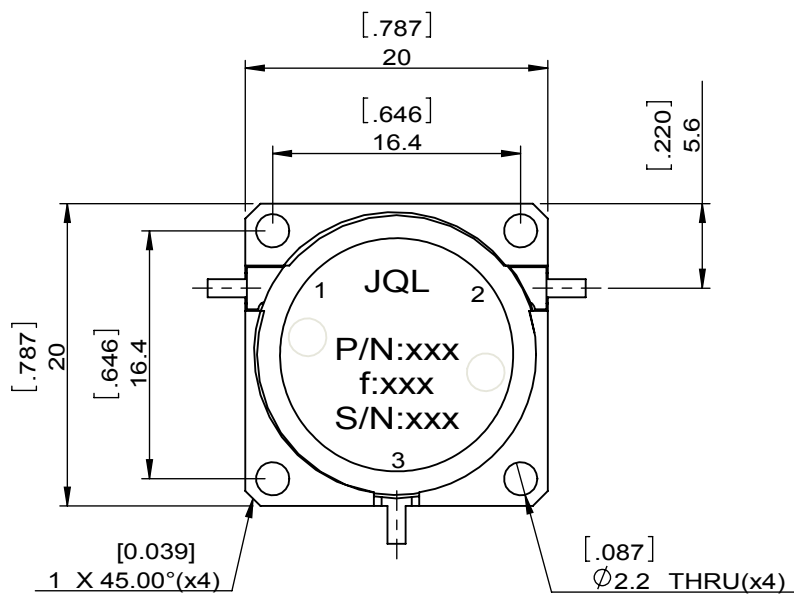

This document is the property of JQL Electronic Inc. It cannot be copied, duplicated, used for manufacturing purposes or communicated to third party as a whole or partly, without the written consent of JQL Electronic Inc.

JQL JQL Electronic Inc				
MATERIAL: STEEL		DWG NO: JCD0860T0960YM10		
SURFACE TREATMENT: NICKEL PLATING		DWG BY:	ZC.Wu	08.26.2014
DESCRIPTION: DROP-IN CIRCULATOR		CHK'D BY:		SCALE
		APPV'D BY:		2:1
Unit: mm[inch]		Tolerance: Liner: ±0.25 Anguar: ±0.5°	The First: 	
				A4