

| | | | | | | | | | | | |
|--------------|---------------|------|-----|-------|-------------|---------|------|----------|--|---|--|
| 1 | | 2 | | 3 | | 4 | | 5 | | 6 | |
| Document No. | QR4-700-T-003 | REV. | A/0 | REV. | DESCRIPTION | REVISOR | DATE | APPROVED | | | |
| REV. | A/0 | 0 | - | ZC.Wu | 06.24.2015 | David | | | | | |

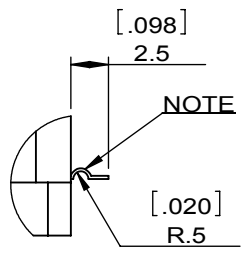
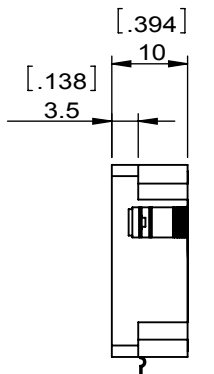
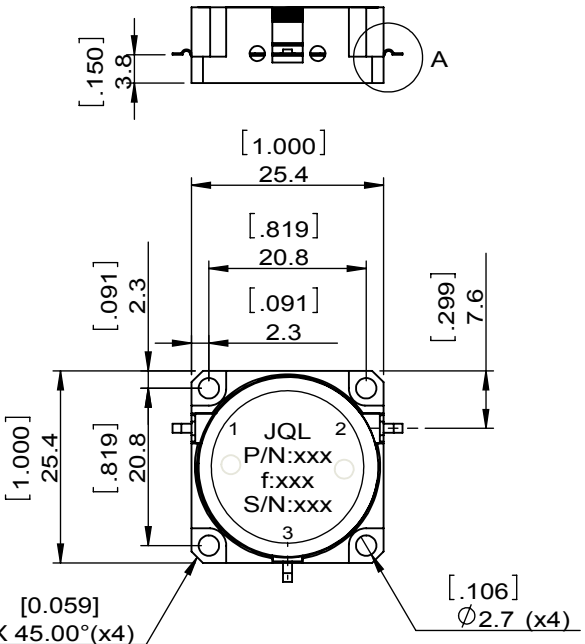
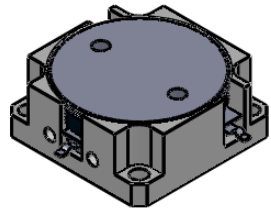

DETAIL A
SCALE 2 : 1

- Note:
- 1.INSERTION PHASE MATCH +/-3 DEGREE AMONG PORTS 1-2,2-3,3-1
 - 2.PHASE MATCH +/-5 DEGREE AMONG PARTS
 - 3.TABS ARE RTV SEALED AT 3 PORTS
 - 4.OMEGE AT TABS
 - 5.SILVER PLATING REMOVAL OF TAB EDGES
 - 6.BARE TAB EDGES WITH TIN LEAD SOLDER DIPPE

- NOTES:
- 1.STANDARD INPUT/OUTPUT 50OHM IMPEDANCE
 - 2.BEO FREE,LEAD FREE,NO Nd MATERIAL
 - 3.RoHS COMPLIANT
 - 4.S-PARAMETERS TO BE MEASURED BY CONECTING PORT 1 AND PORT 2 TO VNA,PORT 3 TO LOAD
 - 5.LOAD RETURN LOSS IS 30dB OR HIGHER WHEN TUNING



This document is the property of JQL Electronic Inc. It cannot be copied, duplicated, used for manufacturing purposes or communicated to third party as a whole or partly, without the written consent of JQL Electronic Inc.

| SPECIFICATIONS | |
|---------------------------------|---|
| Part's Number | JCD0950T1250M25 |
| Frequency(GHz) | 0.950~1.250 |
| Direction | CW |
| Insertion Loss(dB)MAX | 0.50 |
| Isolation(dB)MIN | 17.0 |
| Return Loss(dB)MIN | 16.5 |
| 3rd IMD(dBc)MAX | - |
| Power FWD/REV/PK(Watt) | 250/250/- |
| Operating Temperature(°C) | -40~+85 |
| Storage Temperature(°C) | -55~+125 |
| 2nd/3rd Harmonic(dBc) | - |
| Termination/Attenuator(Watt/dB) | - |
| Tab(W×LG×THK)(mm[Inch]) | TAB: BRASS, 2 um SILVER PLATING OVER 3 um COPPER PLATING 1.2[.047]x2.5[.098]x0.2[0.008]- |
| Additional Notes | - |

| | | | | |
|---|---|-----------------------------------|-------|------------|
| JQL Electronic Inc | | | | |
| MATERIAL: STEEL | | DWG NO: JCD0950T1250M25 | | |
| SURFACE TREATMENT: NICKEL PLATING | | DWG BY: | ZC.Wu | 06.24.2015 |
| DESCRIPTION: DROP-IN CIRCULATOR | | CHK'D BY: | | |
| | | APP'V'D BY: | | |
| Unit: mm[inch] | Tolerance: Liner: ±0.25 Anguar: ±0.5° | The First: | | 1:1 |
| | | | | A4 |