

1		2		3		4		5		6	
Document No.	QR4-700-T-003	REV.	A/0	REV.	DESCRIPTION	REVISOR	DATE	APPROVED			
		0		ZC.Wu	04.14.2015	David					

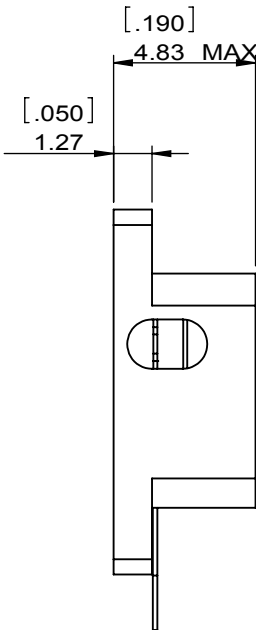

SPECIFICATIONS	
Part's Number	JCD15K0T17K0CM1
Frequency(GHz)	15.000~17.000
Direction	CW
Insertion Loss(dB)MAX	0.6
Isolation(dB)MIN	20.0
Return Loss(dB)MIN	18.0
3rd IMD(dBc)MAX	-
Power FWD/REV/PK(Watt)	5/5/-
Operating Temperature(°C)	-40~+85
Storage Temperature(°C)	--
2nd/3rd Harmonic(dBc)	-
Termination/Attenuator(Watt/dB)	--
Tab(W×LG×THK)(mm[Inch])	0.635[.025]×1.78[.07]×0.13[.005]-
Additional Notes	-

JQL JQL Electronic Inc				
MATERIAL: STEEL		DWG NO: JCD15K0T17K0CM1		
SURFACE TREATMENT: NICKEL PLATING		DWG BY:	ZC.Wu	04.14.2015
DESCRIPTION: DROP-IN CIRCULATOR		CHK'D BY:		SCALE
		APPV'D BY:		4:1
		Unit: mm[inch]	Tolerance: Liner: ±0.25 Anguar: ±0.5°	The First:
				A4

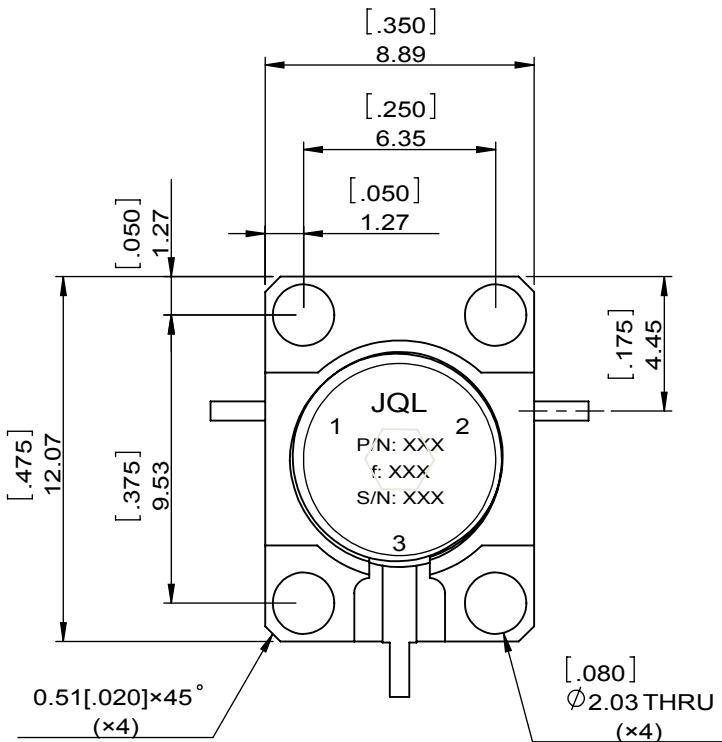
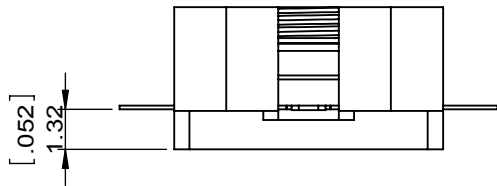
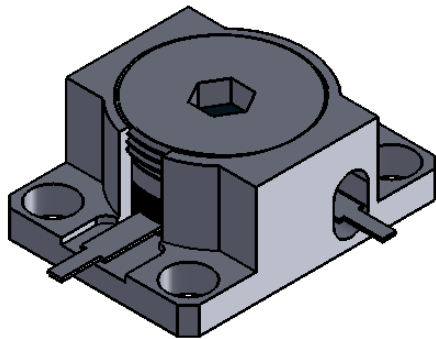

This document is the property of JQL Electronic Inc. It cannot be copied, duplicated, used for manufacturing purposes or communicated to third party as a whole or partly, without the written consent of JQL Electronic Inc.