

1		2		3		4		5		6	
Document No.	QR4-700-T-003	REV.	A/0	REV.	DESCRIPTION	REVISOR	DATE	APPROVED			
				0		LJ.Zhang	12.20.2013	David			

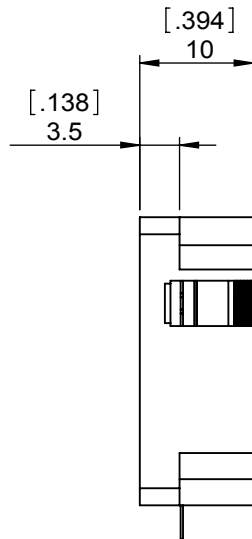

SPECIFICATIONS	
Part's Number	JCD1700T1720M10
Frequency(GHz)	1.700~1.720
Direction	CW
Insertion Loss(dB)MAX	0.25
Isolation(dB)MIN	22.0
Return Loss(dB)MIN	22.0
3rd IMD(dBc)MAX	-
Power FWD/REV/PK(Watt)	100/100/-
Operating Temperature(°C)	-30~+85
Storage Temperature(°C)	-
2nd/3rd Harmonic(dBc)	-
Termination/Attenuator(Watt/dB)	-
Tab(W×LG×THK)(mm[Inch])	1.0[0.039]×2.5[0.10]×0.2[0.008]
Additional Notes	-

NOTES:
 1.STANDARD INPUT/OUTPUT 50OHM IMPEDANCE
 2.BEO FREE,LEAD FREE,NO Nd MATERIAL
 3.RoHS COMPLIANT
 4.S-PARAMETERS TO BE MEASURED BY CONECTING PORT 1 AND PORT 2 TO VNA, PORT 3 TO LOAD
 5.LOAD RETURN LOSS IS 30dB OR HIGHER WHEN TUNING

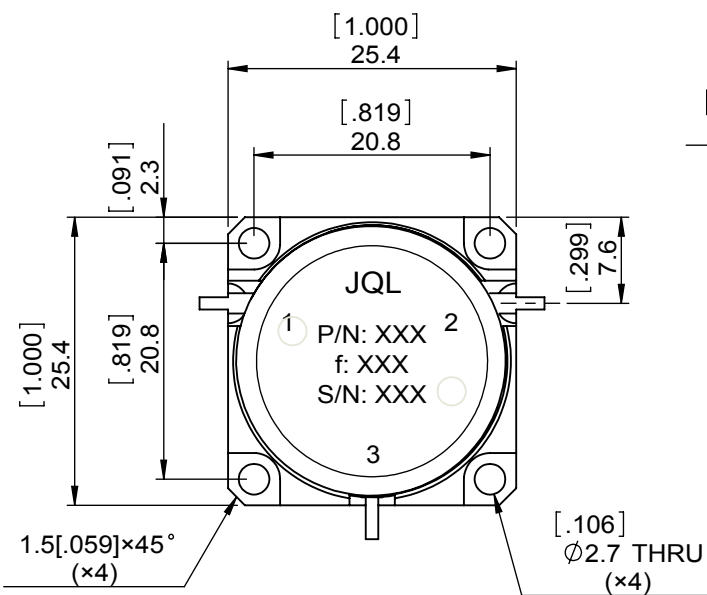
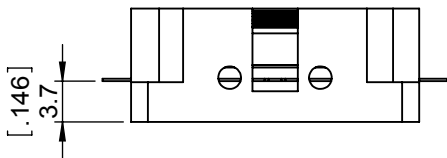
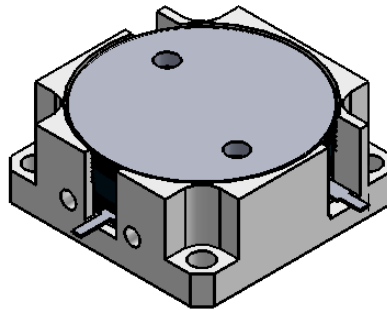

This document is the property of JQL Electronic Inc. It cannot be copied, duplicated, used for manufacturing purposes or communicated to third party as a whole or partly, without the written consent of JQL Electronic Inc.

JQL JQL Electronic Inc		500 Lake Cook Road, Suite 350 Deerfield, IL 60015, USA		Tel: 1(888)236-9828 Fax: 1(888)823-2902	
MATERIAL: STEEL	DWG NO: JCD1700T1720M10				
SURFACE TREATMENT: NICKEL PLATING	DWG BY:	LJ.Zhang	12.20.2013	SACLE	3:2
DESCRIPTION: DROP-IN CIRCULATOR	CHK'D BY:				
	APPV'D BY:				A4
	Unit: mm[inch]	Tolerance: Liner: ±0.25 Anguar: ±0.5°	The First:		