

1	2
Document No.	QR4-700-T-003
REV.	A/0

4	5	6		
REV.	DESCRIPTION	REVISOR	DATE	APPROVED
0		LJ.Zhang	03.24.2014	David

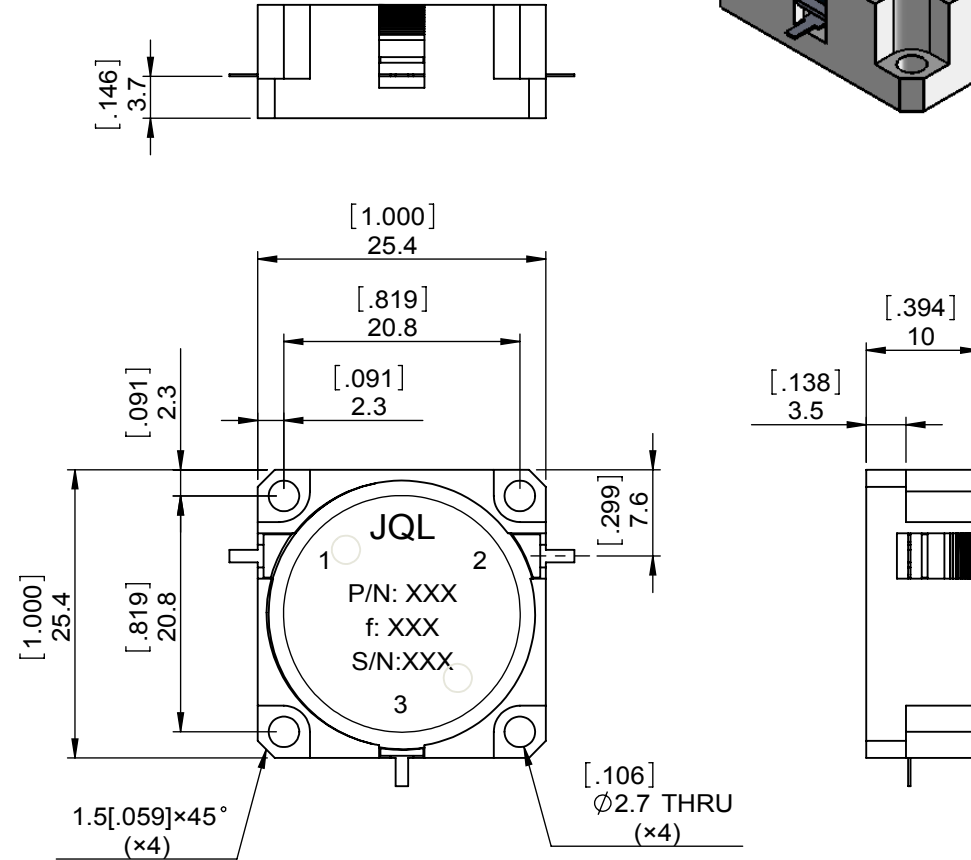
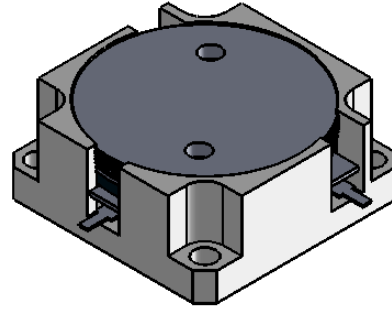

SPECIFICATIONS	
Part's Number	JCD1710T1785M15
Frequency(GHz)	1.710~1.785
Direction	CW
Insertion Loss(dB)MAX	0.3
Isolation(dB)MIN	28.0
Return Loss(dB)MIN	22.0
3rd IMD(dBc)MAX	
Power FWD/REV/PK(Watt)	150/150/-
Operating Temperature(°C)	-20~+80
Storage Temperature(°C)	-
2nd/3rd Harmonic(dBc)	-
Termination/Attenuator(Watt/dB)	-
Tab(W×LG×THK)(mm[Inch])	1.0[.0394]×2.5[.098]×0.2[.008]
Additional Notes	-

- NOTES:
 1.STANDARD INPUT/OUTPUT 50OHM IMPEDANCE
 2.BEO FREE,LEAD FREE,NO Nd MATERIAL
 3.RoHS COMPLIANT
 4.S-PARAMETERS TO BE MEASURED BY CONECTING PORT 1 AND PORT 2 TO VNA, PORT 3 TO LOAD
 5.LOAD RETURN LOSS IS 30dB OR HIGHER WHEN TUNING



This document is the property of JQL Electronic Inc. It cannot be copied, duplicated, used for manufacturing purposes or communicated to third party as a whole or partly, without the written consent of JQL Electronic Inc.

JQL JQL Electronic Inc		500 Lake Cook Road, Suite 350 Deerfield, IL 60015, USA		Tel: 1(888)236-9828 Fax: 1(888)823-2902	
MATERIAL: STEEL		DWG NO: JCD1710T1785M15			
SURFACE TREATMENT: NICKEL PLATING		DWG BY:	LJ.Zhang	03.24.2014	SACLE
DESCRIPTION: DROP-IN CIRCULATOR		CHK'D BY:			
		APPV'D BY:			3:2
		Unit: mm[inch]	Tolerance: Liner: ±0.25 Anguar: ±0.5°	The First:	A4