

1		2		3		4		5		6	
Document No.	QR4-700-T-003	REV.	A/0	REV.	DESCRIPTION	REVISOR	DATE	APPROVED			
				0		M.Hao	09.29.2013	David			

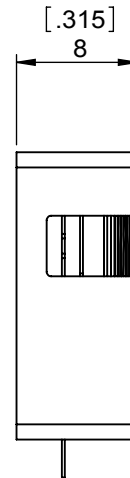

SPECIFICATIONS	
Part's Number	JCD2300T2400SM10
Frequency(GHz)	2.3~2.4
Direction	CW
Insertion Loss(dB)MAX	0.30
Isolation(dB)MIN	23.0
Return Loss(dB)MIN	21.0
3rd IMD(dBc)MAX	
Power FWD/REV/PK(Watt)	100/100/-
Operating Temperature(°C)	-40~+80
Storage Temperature(°C)	-
2nd/3rd Harmonic(dBc)	-
Termination/Attenuator(Watt/dB)	
Tab(W×LG×THK)(mm[Inch])	1.0[0.039]x2.5[0.098]x0.2[0.008]
Additional Notes	-

- NOTES:  
 1.STANDARD INPUT/OUTPUT 50OHM IMPEDANCE  
 2.BEO FREE,LEAD FREE,NO Nd MATERIAL  
 3.RoHS COMPLIANT  
 4.S-PARAMETERS TO BE MEASURED BY CONECTING PORT 1 AND PORT 2 TO VNA, PORT 3 TO LOAD  
 5.LOAD RETURN LOSS IS 30dB OR HIGHER WHEN TUNING

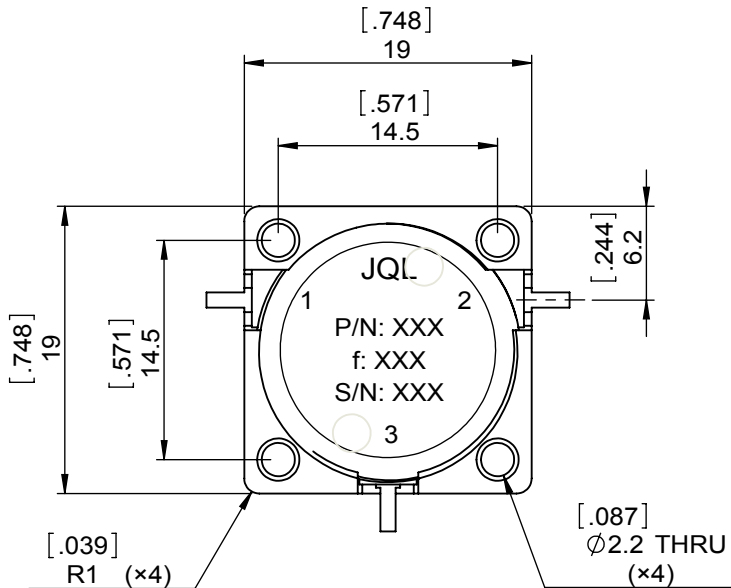
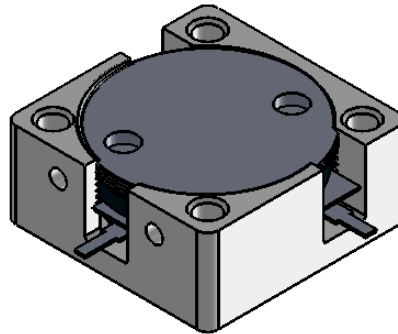
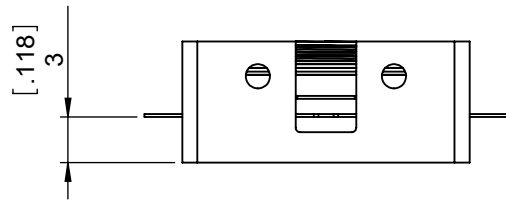

This document is the property of JQL Electronic Inc. It cannot be copied, duplicated, used for manufacturing purposes or communicated to third party as a whole or partly, without the written consent of JQL Electronic Inc.

**JQL** **JQL Electronic Inc** 500 Lake Cook Road, Suite 350 Deerfield, IL 60015, USA Tel: 1(888)236-9828 Fax: 1(888)823-2902

<b>MATERIAL:</b> STEEL	<b>DWG NO:</b> JCD2300T2400SM10			
<b>SURFACE TREATMENT:</b> NICKEL PLATING	DWG BY:	M.Hao	09.29.2013	SACLE
	CHK'D BY:			
<b>DESCRIPTION:</b> DROP-IN CIRCULATOR	APPV'D BY:			2:1
	Unit: mm[inch]	Tolerance: Liner: ±0.25 Anguar: ±0.5°	The First:	A4