

1		2		3		4		5		6	
Document No.	QR4-700-T-003					REV.	DESCRIPTION	REVISOR	DATE	APPROVED	
REV.	A/0					0		LJ.Zhang	11.13.2013	David	

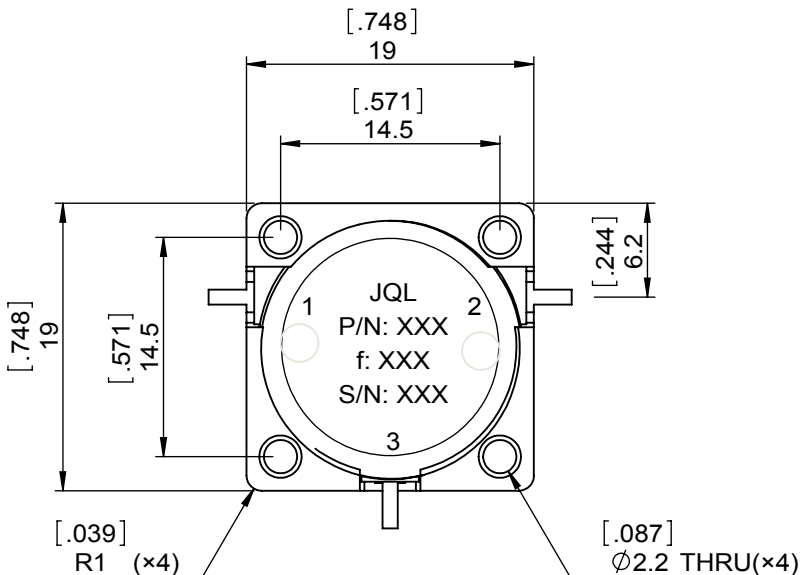

SPECIFICATIONS	
Part's Number	JCD2300T2700SM10
Frequency(GHz)	2.300~2.700
Direction	CW
Insertion Loss(dB)MAX	0.40
Isolation(dB)MIN	20.0
Return Loss(dB)MIN	20.0
3rd IMD(dBc)MAX	-
Power FWD/REV/PK(Watt)	100/100/-
Operating Temperature(°C)	-40~+85
Storage Temperature(°C)	-54~+100
2nd/3rd Harmonic(dBc)	-
Termination/Attenuator(Watt/dB)	-
Tab(W×LG×THK)(mm[Inch])	1[.039]×2.5[.098]×0.2[.008]
Additional Notes	--

- NOTES:
- 1.STANDARD INPUT/OUTPUT 50OHM IMPEDANCE
  - 2.BEO FREE,LEAD FREE,NO Nd MATERIAL
  - 3.RoHS COMPLIANT
  - 4.S-PARAMETERS TO BE MEASURED BYCONNECTING PORT 1 AND PORT 2 TO VNA,PORT 3 TO LOAD
  - 5.LOAD RETURN LOSS IS 30dB OR HIGHER WHEN TUNING

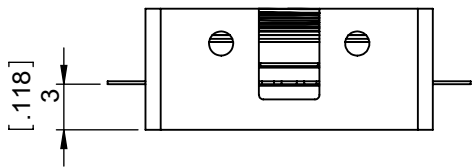
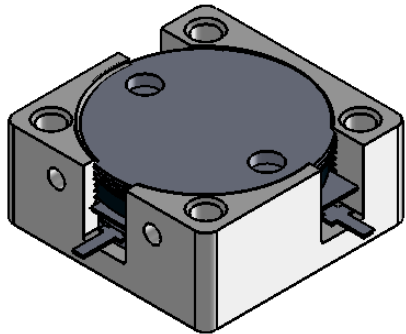

This document is the property of JQL Electronic Inc. It cannot be copied, duplicated, used for manufacturing purposes or communicated to third party as a whole or partly, without the written consent of JQL Electronic Inc.

**JQL** JQL Electronic Inc 500 Lake Cook Road, Suite 350 Deerfield, IL 60015, USA Tel: 1(888)236-9828 Fax: 1(888)823-2902

<b>MATERIAL:</b> STEEL	<b>DWG NO:</b> JCD2300T2700SM10			
<b>SURFACE TREATMENT:</b> NICKEL PLATING	DWG BY:	LJ.Zhang	11.13.2013	SACLE
<b>DESCRIPTION:</b> DROP-IN CIRCULATOR	CHK'D BY:			
	APPV'D BY:			2:1
	Unit: mm[inch]	Tolerance: Liner: ±0.1mm Anguar: ±0.5°	The First:	A4