

| | | | | | | | | | | | |
|--------------|---------------|---|--|---|--|------|-------------|----------|------------|----------|--|
| 1 | | 2 | | 3 | | 4 | | 5 | | 6 | |
| Document No. | QR4-700-T-003 | | | | | REV. | DESCRIPTION | REVISOR | DATE | APPROVED | |
| REV. | A/0 | | | | | 0 | | LJ.Zhang | 08.09.2013 | David | |

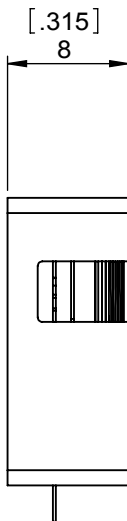
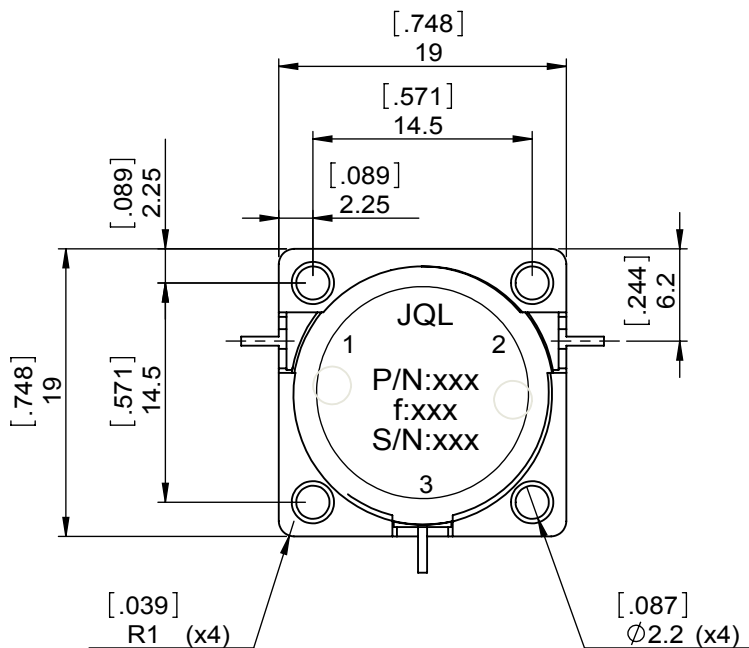
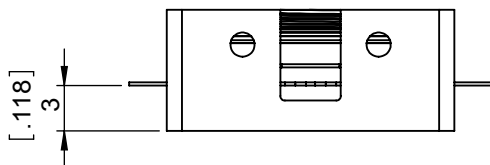
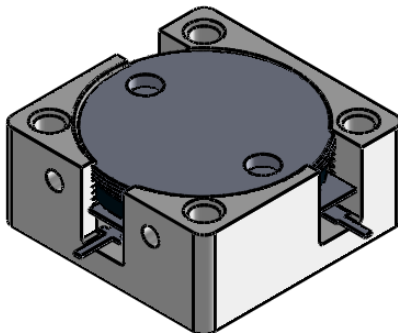

| SPECIFICATIONS | |
|---------------------------------|----------------------------------|
| Part's Number | JCD3100T3500SM10 |
| Frequency(GHz) | 3.100~3.500 |
| Direction | CW |
| Insertion Loss(dB)MAX | 0.30 |
| Isolation(dB)MIN | 20.0 |
| Return Loss(dB)MIN | 21.0 |
| 3rd IMD(dBc)MAX | - |
| Power FWD/REV/PK(Watt) | 120/120/500 |
| Operating Temperature(°C) | -40~85 |
| Storage Temperature(°C) | -55~+100 |
| 2nd/3rd Harmonic(dBc) | - |
| Termination/Attenuator(Watt/dB) | - |
| Tab(W×LG×THK)(mm[Inch]) | 0.6[0.024]x2.5[0.098]x0.2[0.008] |
| Additional Notes | Impedance:50Ohms |

JQL **JQL Electronic Inc** 500 Lake Cook Road, Suite 350 Deerfield, IL 60015, USA Tel: 1(888)236-9828 Fax: 1(888)823-2902

| | | | | |
|---|------------------------------------|---|------------|-------|
| MATERIAL: STEEL | DWG NO: JCD3100T3500SM10 | | | |
| SURFACE TREATMENT: NICKEL PLATING | DWG BY: | LJ.Zhang | 08.09.2013 | SACLE |
| | CHK'D BY: | | | |
| DESCRIPTION: DROP-IN CIRCULATOR | APP'VD BY: | | | 2:1 |
| | Unit: mm[inch] | Tolerance: Liner: ±0.25 Anguar: ±0.5° | The First: | A4 |



This document is the property of JQL Electronic Inc. It cannot be copied, duplicated, used for manufacturing purposes or communicated to third party as a whole or partly, without the written consent of JQL Electronic Inc.