

1	2
Document No.	QR4-700-T-003
REV.	A/0

4	5	6		
REV.	DESCRIPTION	REVISOR	DATE	APPROVED
0		ZC.Wu	09.02.2014	David

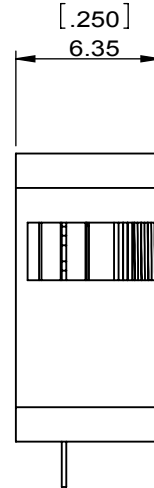
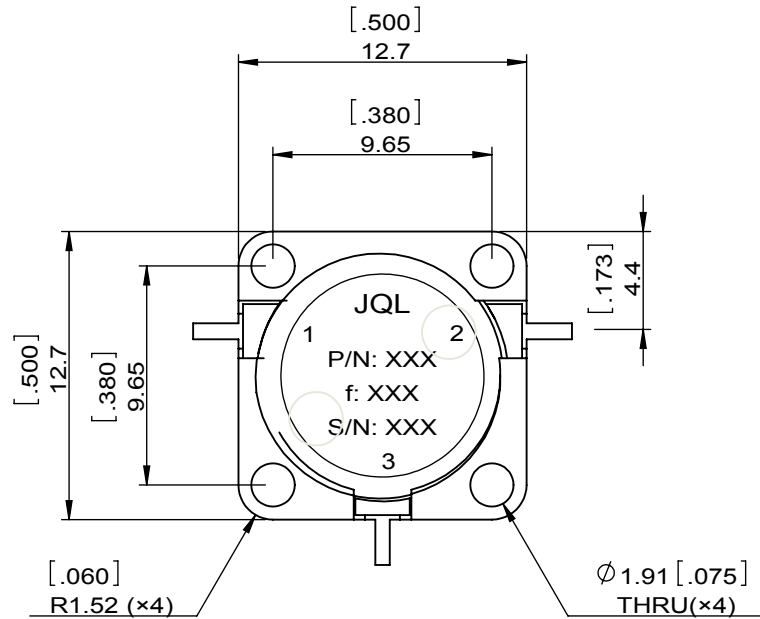
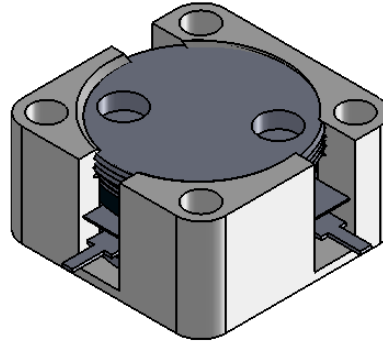
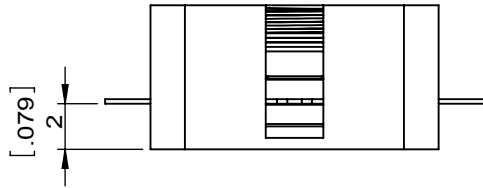

SPECIFICATIONS	
Part's Number	JCD3100T3600VM6R
Frequency(GHz)	3.100~3.600
Direction	CW
Insertion Loss(dB)MAX	0.4
Isolation(dB)MIN	20.0
Return Loss(dB)MIN	20.0
3rd IMD(dBc)MAX	-
Power FWD/REV/PK(Watt)	-/-150W 20% DC & 200us width
Operating Temperature(°C)	-54~+80
Storage Temperature(°C)	
2nd/3rd Harmonic(dBc)	-23dBc
Termination/Attenuator(Watt/dB)	-
Tab(W×LG×THK)(mm[Inch])	0.7[.028]×2.0[.078]×0.2[.008]
Additional Notes	-

- NOTES:
- 1.STANDARD INPUT/OUTPUT 50OHM IMPEDANCE
 - 2.BEO FREE,LEAD FREE,NO Nd MATERIAL
 - 3.RoHS COMPLIANT
 - 4.S-PARAMETERS TO BE MEASURED BYCONNECTING PORT 1 AND PORT 2 TO VNA,PORT 3 TO LOAD
 - 5.LOAD RETURN LOSS IS 30dB OR HIGHER WHEN TUNING



This document is the property of JQL Electronic Inc. It cannot be copied, duplicated, used for manufacturing purposes or communicated to third party as a whole or partly, without the written consent of JQL Electronic Inc.

JQL JQL Electronic Inc				
MATERIAL: STEEL		DWG NO: JCD3100T3600VM6R		
SURFACE TREATMENT: NICKEL PLATING		DWG BY:	ZC.Wu	08.08.2013
DESCRIPTION: DROP-IN CIRCULATOR		CHK'D BY:		SACLE
		APPV'D BY:		3:1
Unit: mm[inch]		Tolerance: Liner: ±0.25 Anguar: ±0.5°	The First: 	
				A4