

1		2		3		4		5		6	
Document No.	QR4-700-T-003	REV.	A/0	REV.	DESCRIPTION	REVISOR	DATE	APPROVED			
		0		ZC.Wu	06.12.2015	David					

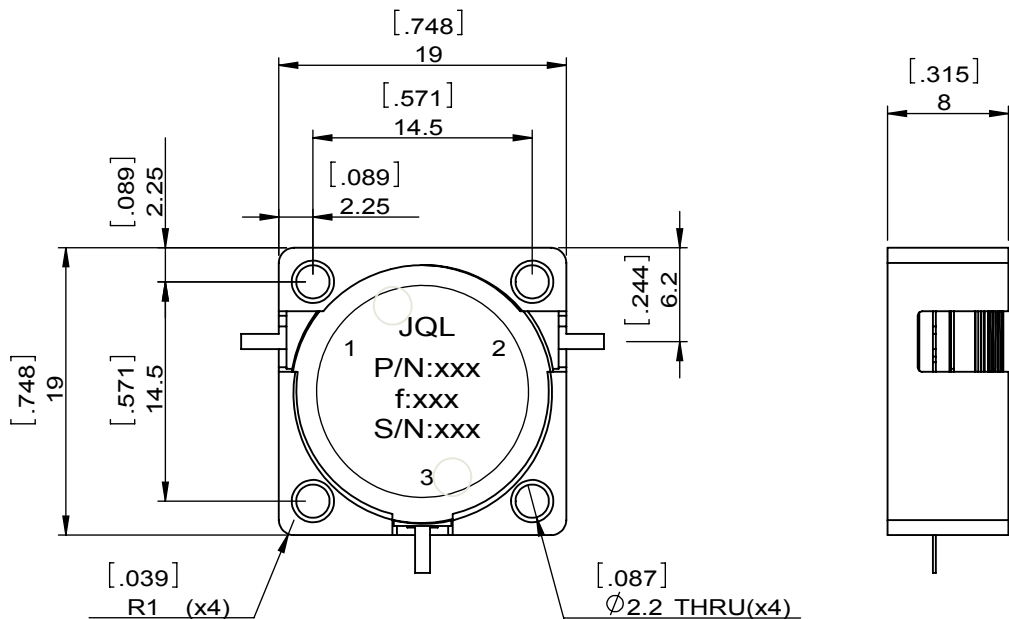
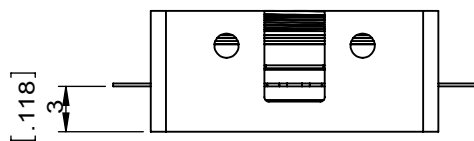
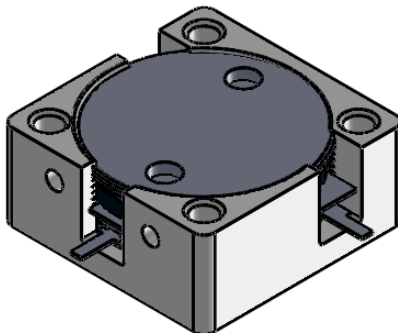

SPECIFICATIONS	
Part's Number	JCD3700T4200SM6
Frequency(GHz)	3.700~4.200
Direction	CW
Insertion Loss(dB)MAX	0.40
Isolation(dB)MIN	20.0
Return Loss(dB)MIN	20.0
3rd IMD(dBc)MAX	
Power FWD/REV/PK(Watt)	60/60/600
Operating Temperature(°C)	-40~+85
Storage Temperature(°C)	-
2nd/3rd Harmonic(dBc)	-
Termination/Attenuator(Watt/dB)	-
Tab(W×LG×THK)(mm[Inch])	1.0[.039]x2.5[.098]x0.2[.008]
Additional Notes	

NOTES:

- 1.STANDARD INPUT/OUTPUT 50OHM IMPEDANCE
- 2.BEO FREE,LEAD FREE,NO Nd MATERIAL
- 3.RoHS COMPLIANT
- 4.S-PARAMETERS TO BE MEASURED BY CONECTING PORT 1 AND PORT 2 TO VNA,PORT 3 TO LOAD
- 5.LOAD RETURN LOSS IS 30dB OR HIGHER WHEN TUNING



This document is the property of JQL Electronic Inc. It cannot be copied, duplicated, used for manufacturing purposes or communicated to third party as a whole or partly, without the written consent of JQL Electronic Inc.

JQL JQL Electronic Inc				
MATERIAL: STEEL		DWG NO: JCD3700T4200SM6		
SURFACE TREATMENT: NICKEL PLATING		DWG BY:	ZC.Wu	06.12.2015
DESCRIPTION: DROP-IN CIRCULATOR		CHK'D BY:		SCALE
		APPV'D BY:		2:1
		Unit: mm[inch]	Tolerance: Liner: ±0.25 Anguar: ±0.5°	The First:
				A4