

1		2		3		4		5		6	
Document No. QR4-700-T-003								REV.		DESCRIPTION	
REV. A/0								0		LJ.Zhang	
								07.04.2013		DATE	
										APPROVED	
										David	

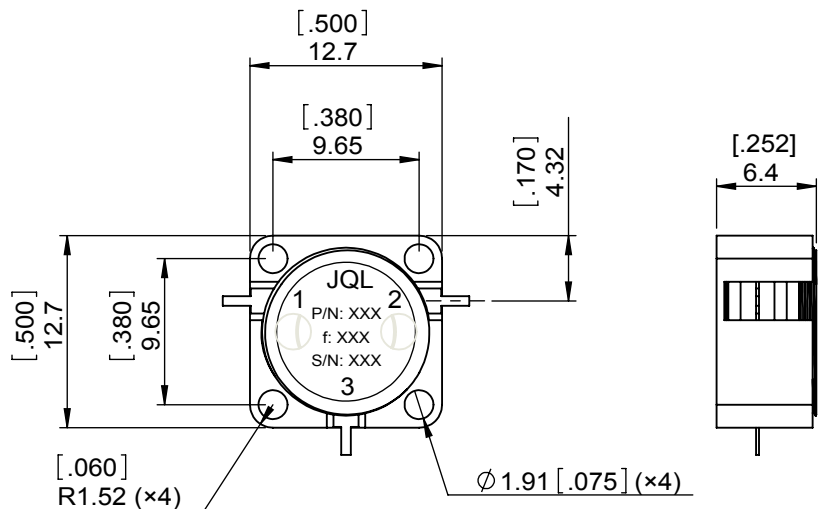
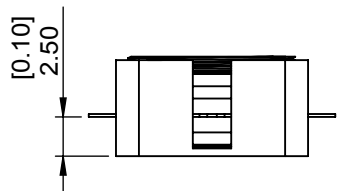
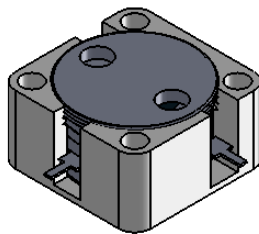

SPECIFICATIONS	
Part's Number	JCD9200T9800VM0
Frequency(GHz)	9.200~9.800
Direction	CW
Insertion Loss(dB)MAX	0.30
Isolation(dB)MIN	20.0
Return Loss(dB)MIN	20.0
3rd IMD(dBc)MAX	-
Power FWD/REV/PK(Watt)	5/5/25/-
Operating Temperature(°C)	-40~75
Storage Temperature(°C)	
2nd/3rd Harmonic(dBc)	-
Termination/Attenuator(Watt/dB)	-
Tab(W×LG×THK)(mm[Inch])	0.7[0.276]×1.8[0.07]×0.2[0.01]
Additional Notes	-

JQL **JQL Electronic Inc** 500 Lake Cook Road, Suite 350 Deerfield, IL 60015, USA Tel: 1(888)236-9828 Fax: 1(888)823-2902

MATERIAL: STEEL	DWG NO: JCD9200T9800VM0			
SURFACE TREATMENT: NICKEL PLATING	DWG BY:	LJ.Zhang	07.04.2013	SACLE
	CHK'D BY:			
DESCRIPTION: DROP-IN CIRCULATOR	APPV'D BY:			1:1
	Unit: mm[inch]	Tolerance: Liner: ±0.25 Anguar: ±0.5°	The First:	A4



This document is the property of JQL Electronic Inc. It cannot be copied, duplicated, used for manufacturing purposes or communicated to third party as a whole or partly, without the written consent of JQL Electronic Inc.