

Document No. QR4-700-T-003

REV. A/0

REV.	DESCRIPTION	REVISOR	DATE	APPROVE
0		MH	02.20.13	CH

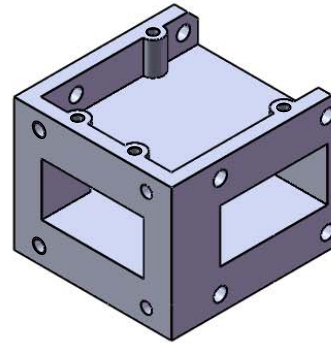
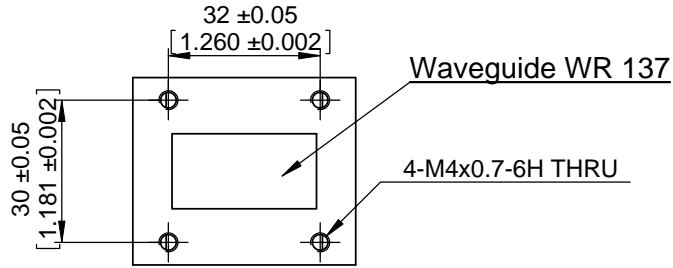

SPECIFICATION

Part's Number: JCWR137-47-5600T6400
 Frequency: 5.600~6.400GHz
 Part's Number: JCWR137-47-6400T7100
 Frequency: 6400~7100GHz
 Part's Number: JCWR137-47-7100T7900
 Frequency: 7100~7900GHz
 Part's Number: JCWR137-47-7700T8500
 Frequency: 7700~8500GHz

Direction: CW
 Insertion Loss: 0.15dB MAX.
 Isolation: 28.0dB MIN.
 RL: 28.0dB MIN.

Temperature: -40°C~+55°C
 Altitude:
 Operating: Up to 15,000 FT
 Non Operating: Up to 50,000 FT

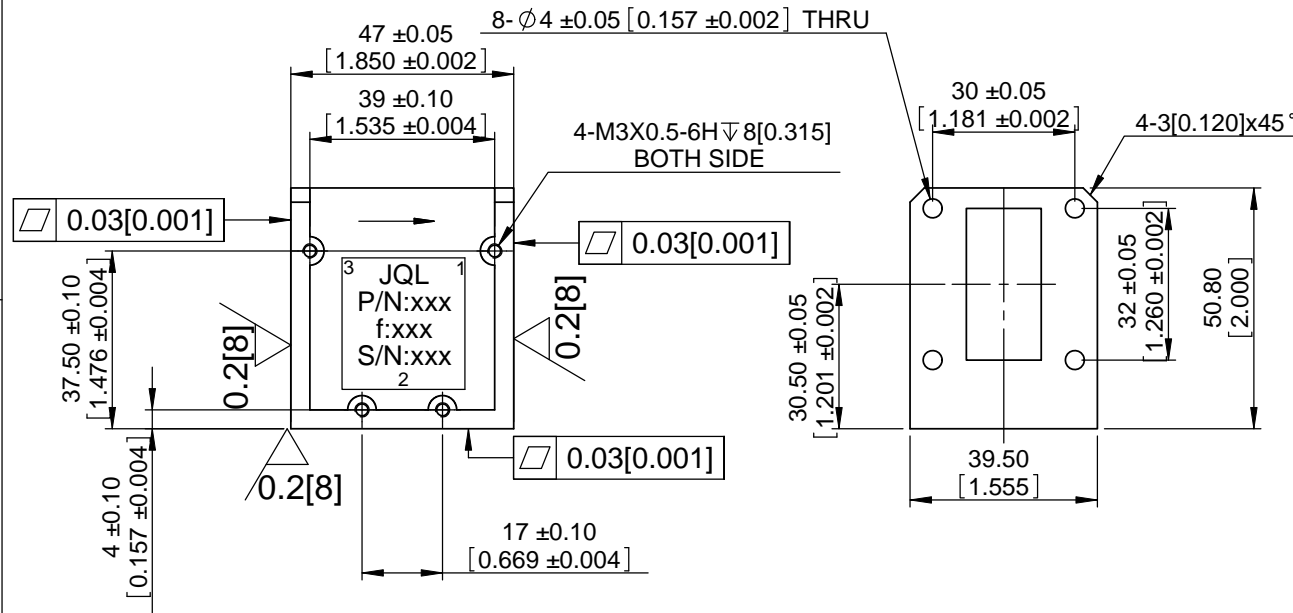

This document is the property of JQL Electronic Inc.
 It cannot be copied, duplicated, used for manufacturing purposes
 or communicated to third party as a whole or partly,
 without the written consent of JQL Electronic Inc.

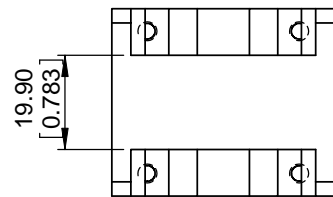

NOTES:PART MUST BE COMPLIANCE WITH 168H IN SALT MIST SPRAY.

JQL JQL Electronic Inc

500 Lake Cook Road, Suite 350 Tel : 1(888)236-9828
 Deerfield, IL 60015, USA Fax: 1(630)823-2902

MATERIAL:
ALUMINUM
 SURFACE TREATMENT:
CHEM FILM
 DESCRIPTION:
W/G CIRCULATOR

DWG NO. JCWR137-47-5600T6400
 JCWR137-47-6400T7100
 JCWR137-47-7100T7900
 JCWR137-47-7700T8500

	NAME	DATE	SCALE:
DWG BY:	MH	02.20.13	1:1
CHK'D BY:			
APPVD BY:			
Unit: mm	TOLERANCE: Liner: ±0.1mm Angular: ±0.5°	Type Of Projection	A4

WEIGHT:

SHEET 1 OF 1