

Document No. QR4-700-T-003

REV. A/0

REV.	DESCRIPTION	REVISOR	DATE	APPROVE
0		HM	12.08.12	CH

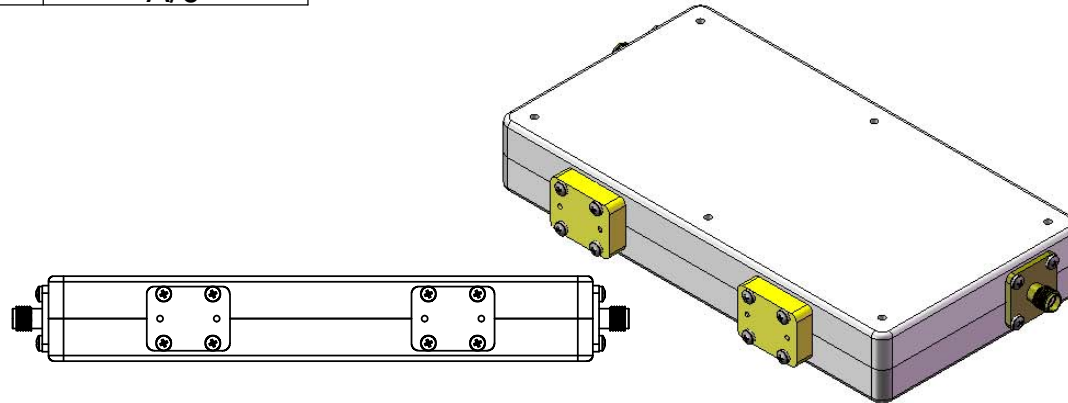

**SPECIFICATIONS**

P/N: JI2C0150T0174MS1  
 FREQ: 0.150~0.174GHz

CIRCULATION: CW  
 ISOLATION: 40dB MIN  
 INS LOSS: 0.8dB MAX  
 VSWR: 1.25:1 MAX  
 PWR FWD/REV 100W/10W  
 TERMINATION: 100W  
 CONNECTOR: SMA-F  
 TEMP: -10C~+60C

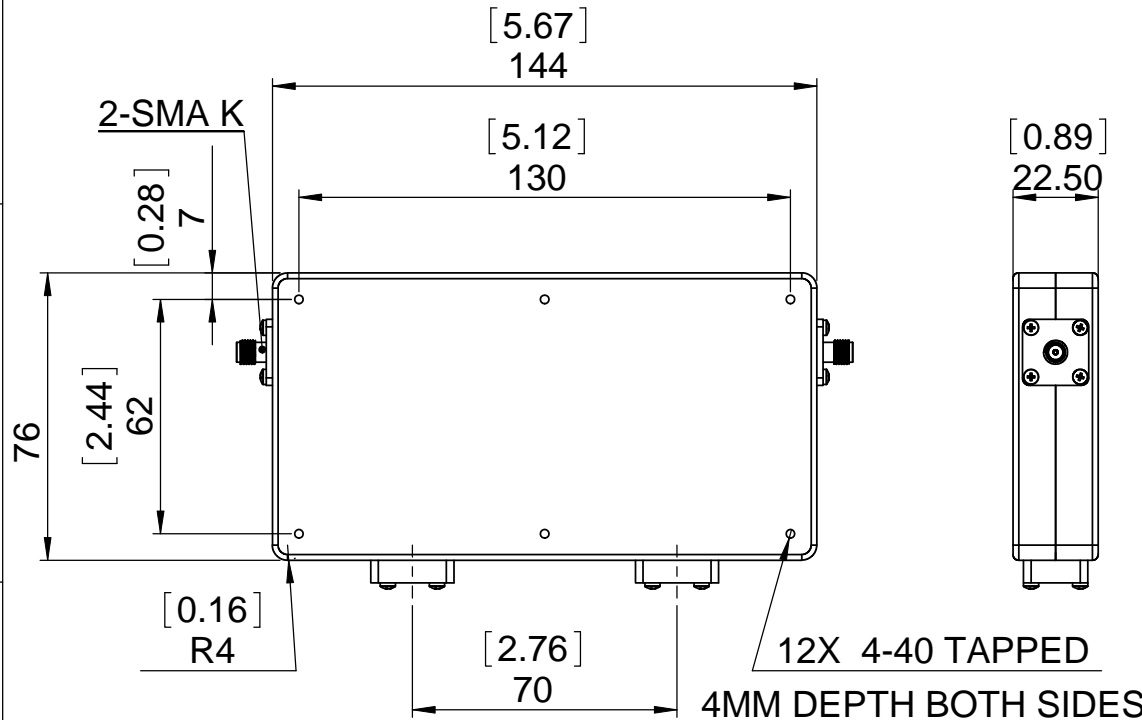

**JQL Electronic Inc**

MATERIAL: <b>STEEL</b>	DWG NO. <b>JI2C0150T0174MS1</b>		
SURFACE TREATMENT:	NAME	DATE	SCALE:
	DWG BY: <b>HM</b>	12.08.12	<b>1:2</b>
DESCRIPTION: <b>COAX ISOLATOR</b>	APP'VD BY:		
Unit: mm[inch]	TOLERANCE: Liner: ±0.1mm Angular: ±0.5°	Type Of Projection	<b>A4</b>



This document is the property of JQL Electronic Inc. It cannot be copied, duplicated, used for manufacturing purposes or communicated to third party as a whole or partly, without the written consent of JQL Electronic Inc.

WEIGHT: