

5		6		
REV.	DESCRIPTION	REVISOR	DATE	APPROVE

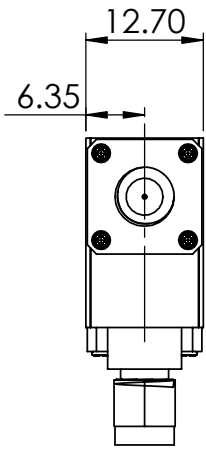

**SPECIFICATIONS**  
P/N: JI2C4200T4400SFTSM1  
FREQ: 4.2~4.4GHz  
ISOLATION: 40dB MIN  
INS LOSS TYP/MAX 0.4/0.6 MAX  
VSWR: 1.25:1 MAX  
POWER FWD/REV 20/10  
TEMP: -54~+94  
CONNECTOR: OUTPUT SMA-F  
INPUT SMA-M

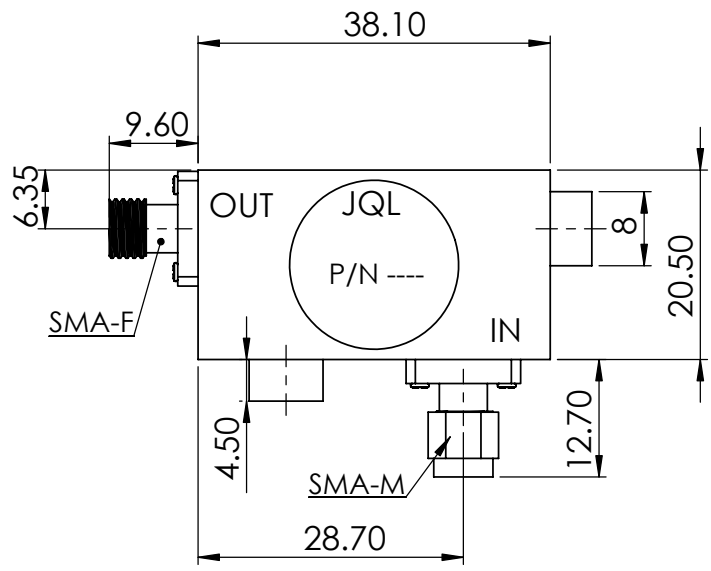
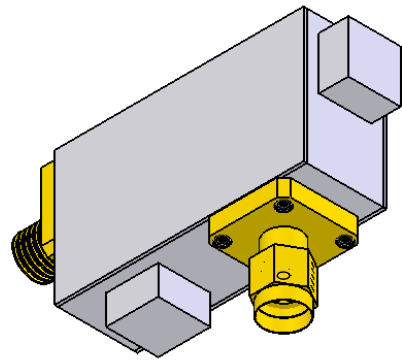

This document is the property of JQL Electronic Inc.  
It cannot be copied, duplicated, used for manufacturing purposes  
or communicated to third party as a whole or partly,  
without the written consent of JQL Electronic Inc.

<b>JQL</b> JQL Electronic Inc				
MATERIAL:		DWG NO.		
SURFACE TREATMENT:		JI2C4200T4400SFTSM1		
DESCRIPTION:		NAME	DATE	SIGNATURE
		DWG BY:		
		CHK'D BY:		
		APPV'D BY		REV: 0
		TOLERANCE Liner: ±0.1mm Angular: ±0.5°		Q.A A4