

1		2		3		4		5		6	
Document No.	QR4-700-T-003	REV.	A/0	REV.	DESCRIPTION	REVISOR	DATE	APPROVED			
		0		LJ.Zhang	11.08.2013	David					

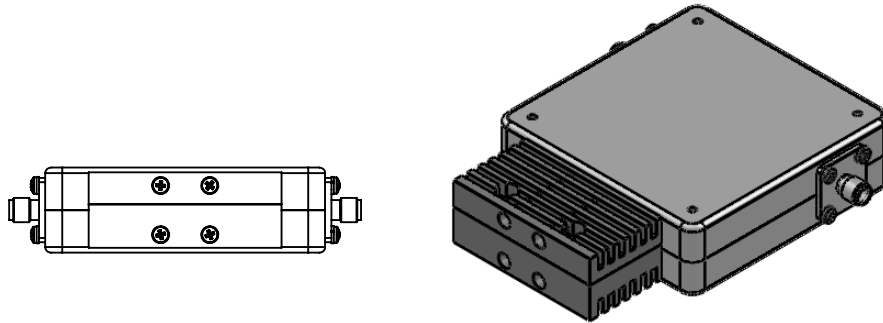

SPECIFICATIONS	
Part's Number	JIC0155T0175S10
Frequency(GHz)	0.155~0.175
Direction	-
Insertion Loss(dB)MAX	0.50
Isolation(dB)MIN	20.0
Return Loss(dB)MIN	19.0
3rd IMD(dBc)MAX	-
Power FWD/REV/PK(Watt)	150/100/-
Operating Temperature(°C)	-30~+70
Storage Temperature(°C)	-
2nd/3rd Harmonic(dBc)	-
Termination/Attenuator(Watt/dB)	100
Tab(W×LG×THK)(mm[Inch])	-
Additional Notes	-

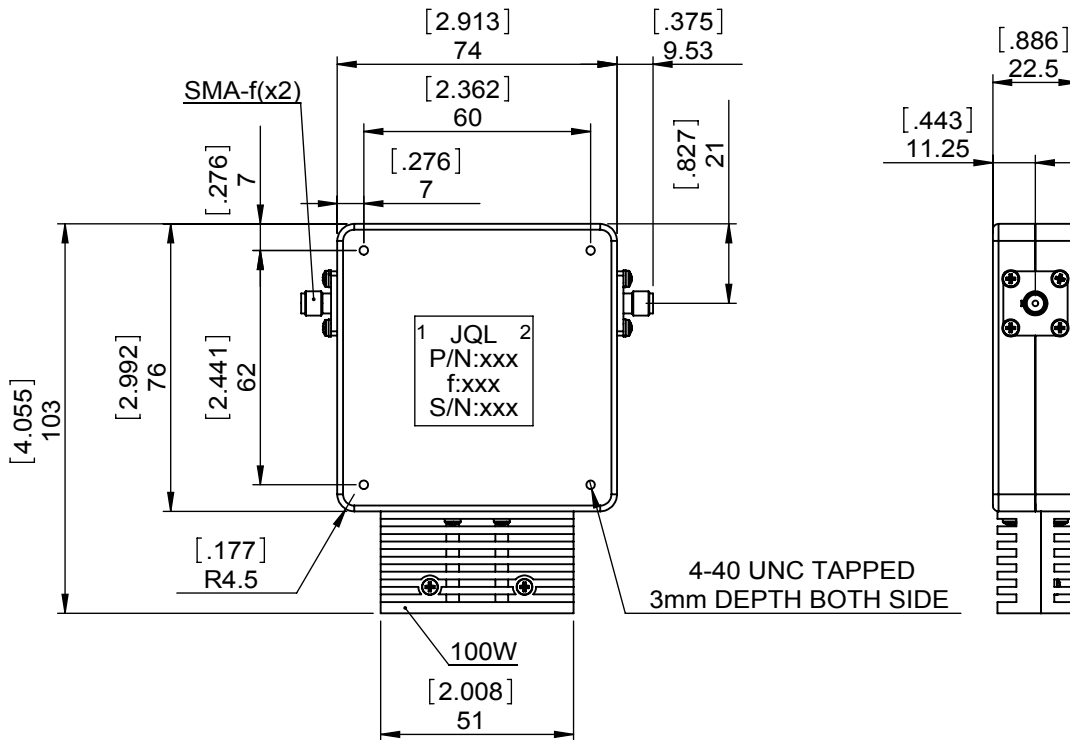

<b>JQL JQL Electronic Inc</b>				
<b>MATERIAL:</b> STEEL		<b>DWG NO:</b> JIC0155T0175S10		
<b>SURFACE TREATMENT:</b> NICKEL PLATING		DWG BY:	LJ.Zhang	11.08.2013
<b>DESCRIPTION:</b> COAX ISOLATOR		CHK'D BY:		SACLE
		APPV'D BY:		1:2
		Unit: mm[inch]	Tolerance: Liner: ±0.25 Anguar: ±0.5°	The First: 
				A4



This document is the property of JQL Electronic Inc. It cannot be copied, duplicated, used for manufacturing purposes or communicated to third party as a whole or partly, without the written consent of JQL Electronic Inc.