

5		6		
REV.	DESCRIPTION	REVISOR	DATE	APPROVE

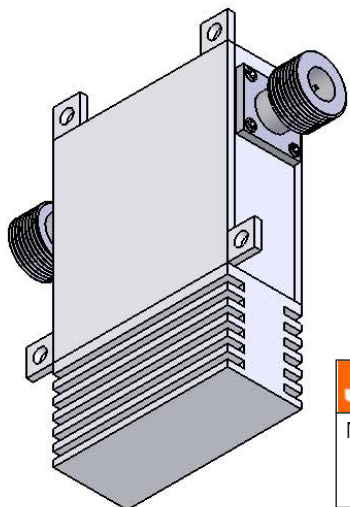
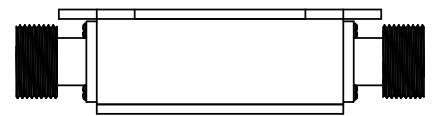
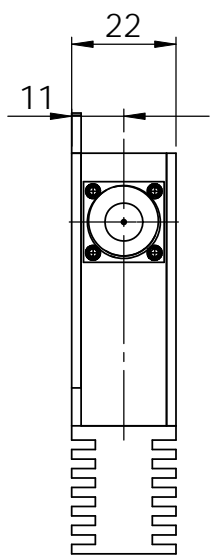
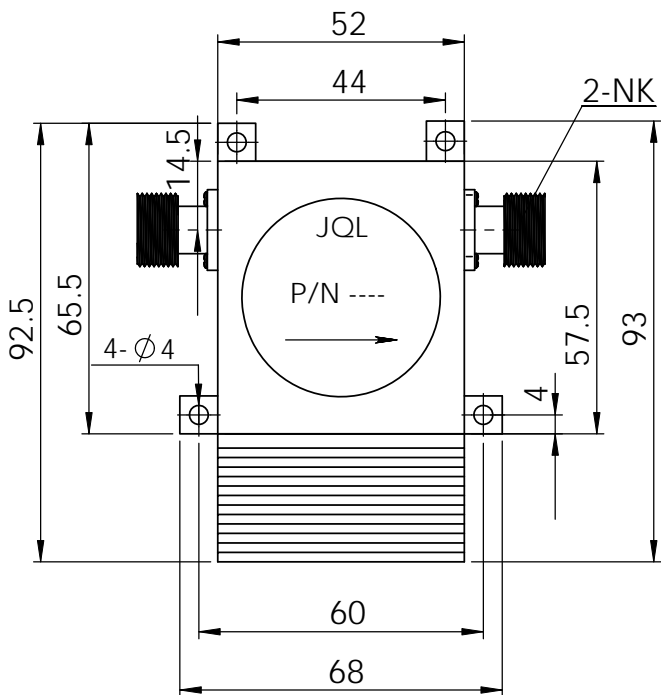

SPECIFICATIONS

P/N: JIC0300T0420S10
 FREQ: 0.300~0.420GHz

ISOLATION: 18dB MIN
 INS LOSS: 0.5dB MAX
 VSWR: 1.35:1 MAX
 PWR FWD/REV: 150W/100W
 CONNECTOR: SMA-F
 TEMPERATURE
 OPERATING: -20~+60C
 STORAGE: -55C~+125C

This document is the property of JQL Electronic Inc.
 It cannot be copied, duplicated, used for manufacturing purposes
 or communicated to third party as a whole or partly,
 without the written consent of JQL Electronic Inc.

CONNECTOR OPTION: N-F BY DEFAULT
 N-M, SMA-F, SMA-M OPTION

JQL JQL Electronic Inc

MATERIAL: STEEL
 SURFACE TREATMENT: NICKEL PLATING
 DESCRIPTION: COAX ISOLATOR

DWG NO. JIC0300T0420S10

DWG BY:	NAME	DATE	SIGNATURE	REV:
CHK'D BY:				0
APPV'D BY:				A4

TOLERANCE
 Liner: ±0.1mm
 Angular: ±0.5°

Q.A