

5		6		
REV.	DESCRIPTION	REVISOR	DATE	APPROVE

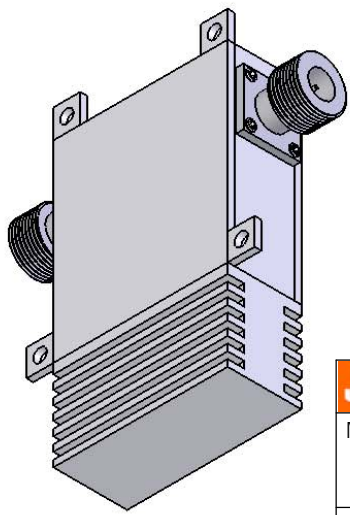
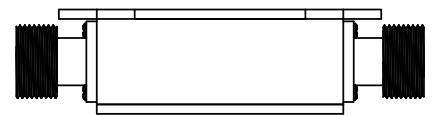
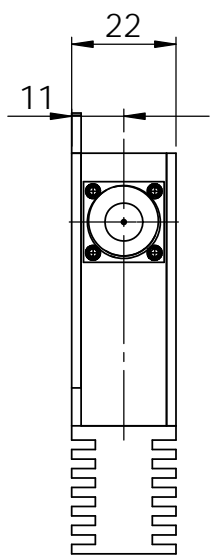
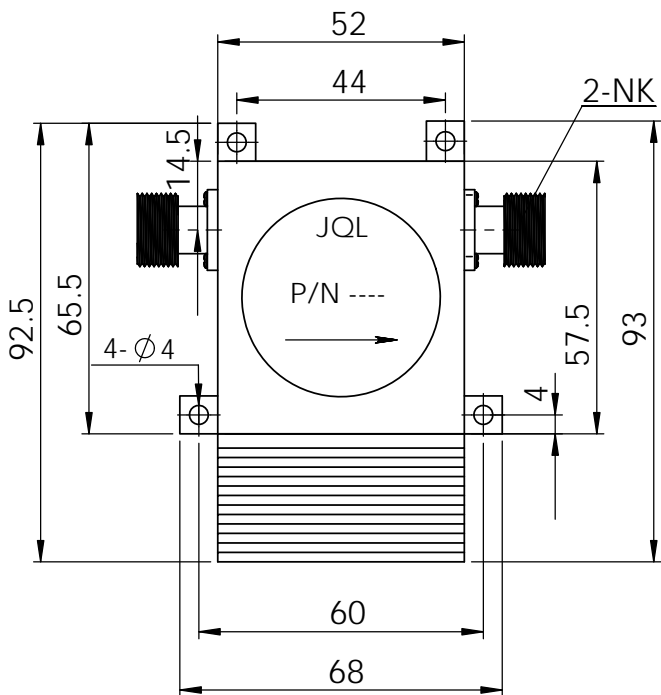

SPECIFICATIONS

P/N: JIC0390T0450N15
 FREQ: 0.390~0.450GHz

ISOLATION: 20dB MIN
 INS LOSS: 0.4dB MAX
 VSWR: 1.25:1 MAX
 PWR FWD/REV: 300W/150W
 CONNECTOR: N-F
 TEMPERATURE OPERATING: -20~+60C
 STORAGE: -55C~+125C

This document is the property of JQL Electronic Inc. It cannot be copied, duplicated, used for manufacturing purposes or communicated to third party as a whole or partly, without the written consent of JQL Electronic Inc.

JQL JQL Electronic Inc

MATERIAL: STEEL	DWG NO. JIC0390T0450N15			
SURFACE TREATMENT: NICKEL PLATING	NAME	DATE	SIGNATURE	REV:
DESCRIPTION: COAX ISOLATOR	DWG BY:			0
	CHK'D BY:			
	APPV'D BY:			
	TOLERANCE Liner: ±0.1mm Angular: ±0.5°		Q.A	A4