

1		2		3		4		5		6	
Document No.	QR4-700-T-003	REV.	A/0	REV.	DESCRIPTION	REVISOR	DATE	APPROVED			
		0		ZC.Wu	10.09.2014	David					

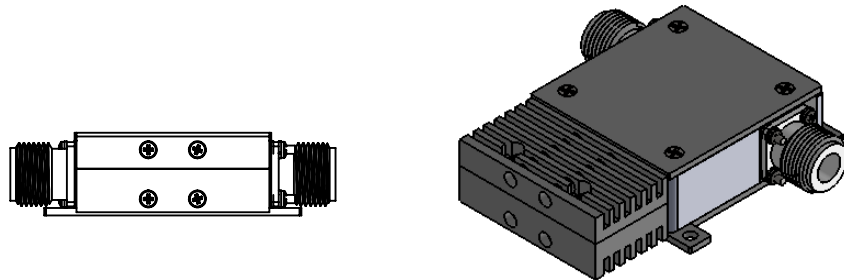

SPECIFICATIONS	
Part's Number	JIC0459T0512N6
Frequency(GHz)	0.459~0.512
Direction	CW
Insertion Loss(dB)MAX	0.30
Isolation(dB)MIN	25.0
Return Loss(dB)MIN	22.0
3rd IMD(dBc)MAX	-
Power FWD/REV/PK(Watt)	125/60/-
Operating Temperature(°C)	-20~+80
Storage Temperature(°C)	-
2nd/3rd Harmonic(dBc)	-
Termination/Attenuator(Watt/dB)	100
Tab(W×LG×THK)(mm[Inch])	-
Additional Notes	-

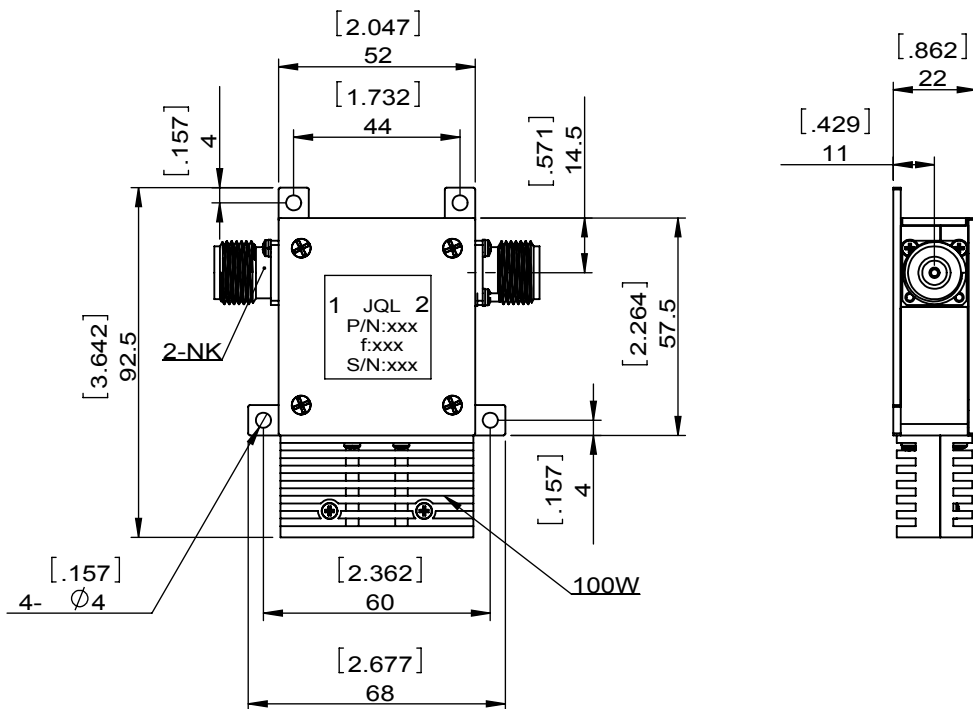

This document is the property of JQL Electronic Inc. It cannot be copied, duplicated, used for manufacturing purposes or communicated to third party as a whole or partly, without the written consent of JQL Electronic Inc.

<b>JQL Electronic Inc</b>				
<b>MATERIAL:</b> STEEL		<b>DWG NO:</b> JIC0459T0512N6		
<b>SURFACE TREATMENT:</b> NICKEL PLATING		DWG BY:	ZC.Wu	10.09.2014
<b>DESCRIPTION:</b> COAXIAL ISOLATOR		CHK'D BY:		SCALE
		APPV'D BY:		1:2
Unit: mm[inch]	Tolerance: Liner: ±0.25 Anguar: ±0.5°	The First:		A4