

REV.	DESCRIPTION	REVISOR	DATE	APPROVE

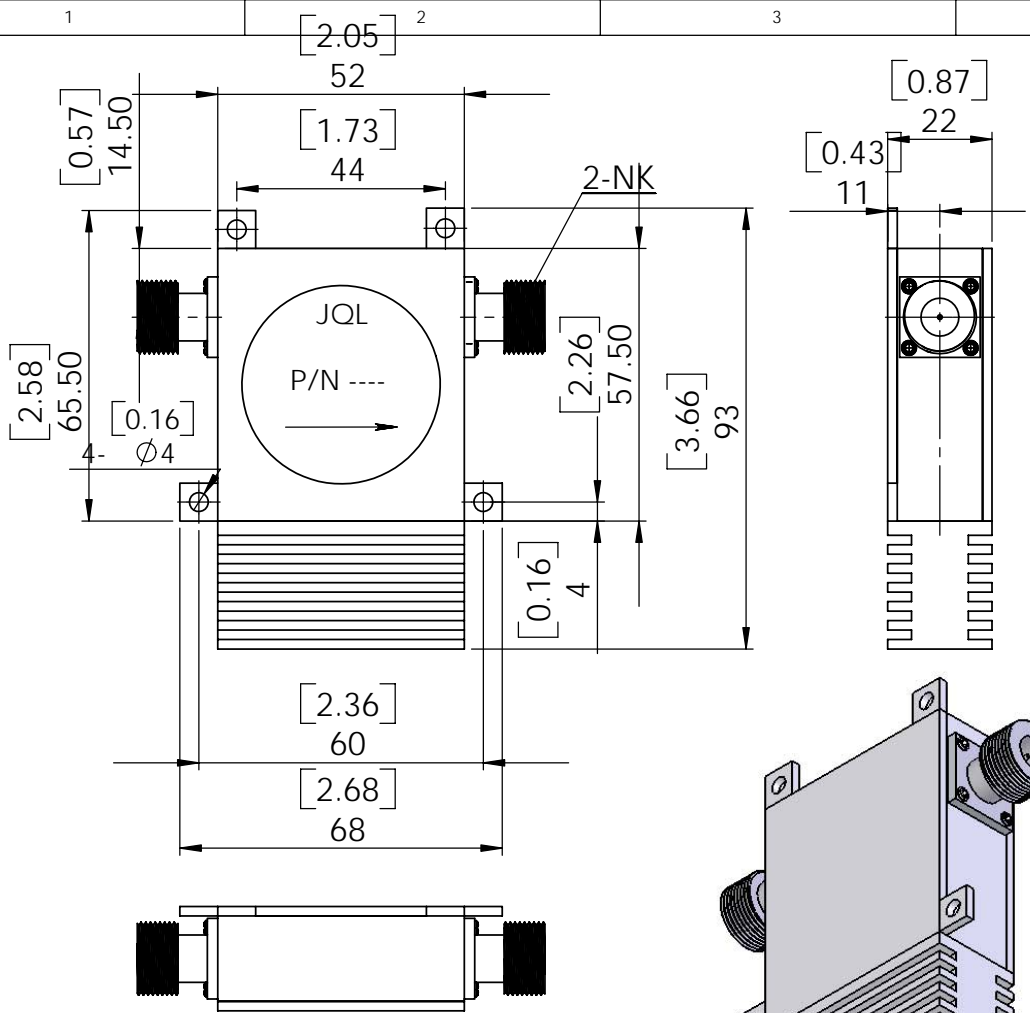

**SPECIFICATIONS**

P/N: JIC0465T0530N6  
 FREQ: 0.465~0.530GHz

ISOLATION: 25dB MIN  
 INS LOSS: 0.25dB MAX  
 VSWR: 1.20:1 MAX  
 PWR FWD/REV: 100W/60W  
 TERMINATION: 100W  
 CONNECTOR: N-F  
 TEMPERATURE OPERATING: -20~+60C  
 STORAGE: -55C~+125C

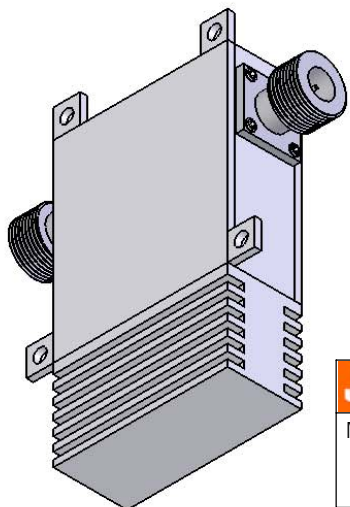

This document is the property of JQL Electronic Inc. It cannot be copied, duplicated, used for manufacturing purposes or communicated to third party as a whole or partly, without the written consent of JQL Electronic Inc.

**JQL** JQL Electronic Inc

MATERIAL: <b>STEEL</b>	DWG NO. JIC00465T0530N6																								
SURFACE TREATMENT: <b>NICKEL PLATING</b>																									
DESCRIPTION: <b>COAX ISOLATOR</b>	<table border="1"> <thead> <tr> <th>NAME</th> <th>DATE</th> <th>SIGNATURE</th> <th>REV:</th> </tr> </thead> <tbody> <tr> <td>DWG BY:</td> <td> </td> <td> </td> <td> </td> </tr> <tr> <td>CHK'D BY:</td> <td> </td> <td> </td> <td> </td> </tr> <tr> <td>APPV'D BY:</td> <td> </td> <td> </td> <td> </td> </tr> <tr> <td> </td> <td> </td> <td> </td> <td> </td> </tr> <tr> <td> </td> <td> </td> <td> </td> <td> </td> </tr> </tbody> </table>	NAME	DATE	SIGNATURE	REV:	DWG BY:				CHK'D BY:				APPV'D BY:											
NAME	DATE	SIGNATURE	REV:																						
DWG BY:																									
CHK'D BY:																									
APPV'D BY:																									
	TOLERANCE Liner: ±0.1mm Angular: ±0.5°	Q.A	A4																						