

1		2		3		4		5		6	
Document No.	QR4-700-T-003	REV.	A/0	REV.	DESCRIPTION	REVISOR	DATE	APPROVED			
				0		ZC.Wu	09.03.2014	David			

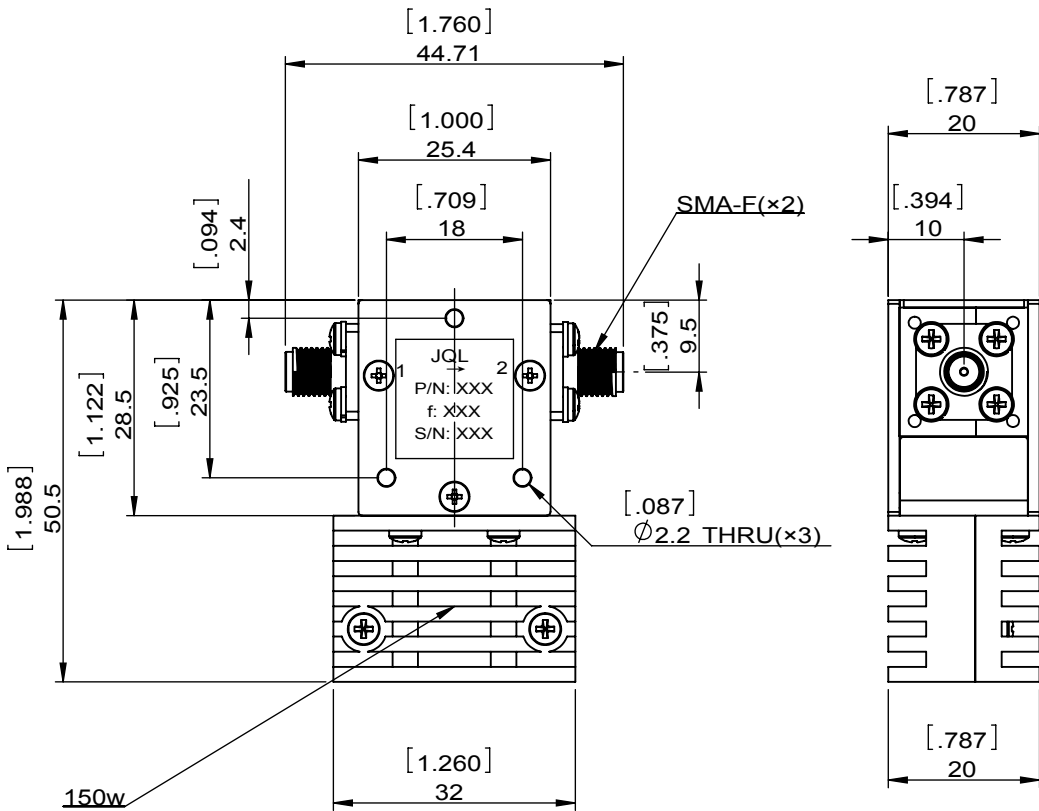

SPECIFICATIONS	
Part's Number	JIC2100T2200S10
Frequency(GHz)	2.100~2.200
Direction	-
Insertion Loss(dB)MAX	0.3
Isolation(dB)MIN	22.0
Return Loss(dB)MIN	22.0
3rd IMD(dBc)MAX	-
Power FWD/REV/PK(Watt)	100/100/-
Operating Temperature(°C)	-20~+80
Storage Temperature(°C)	-
2nd/3rd Harmonic(dBc)	-
Termination/Attenuator(Watt/dB)	150/-
Tab(W×LG×THK)(mm[Inch])	-
Additional Notes	-

<b>JQL</b> JQL Electronic Inc				
<b>MATERIAL:</b> STEEL		<b>DWG NO:</b> JIC2100T2200S10		
<b>SURFACE TREATMENT:</b> NICKEL PLATING		DWG BY:	ZC.Wu	09.03.2014
<b>DESCRIPTION:</b> COAXIAL ISOLATOR		CHK'D BY:		SCALE
		APPV'D BY:		1:1
Unit:		Tolerance:	The First:	A4
mm[inch]		Liner: ±0.25		
		Anguar: ±0.5°		

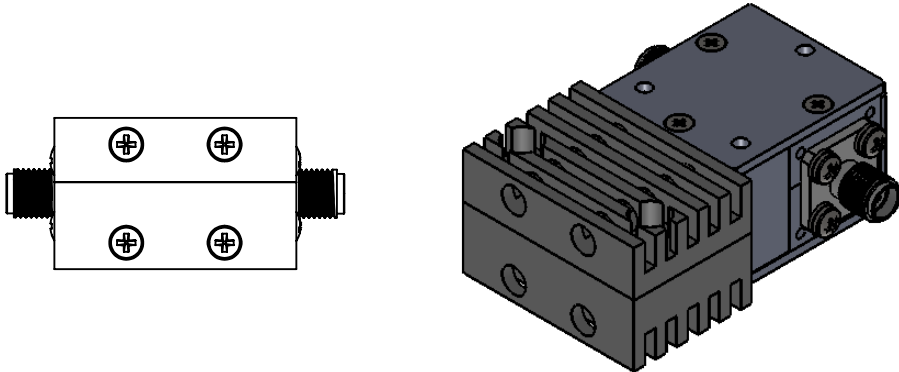

This document is the property of JQL Electronic Inc. It cannot be copied, duplicated, used for manufacturing purposes or communicated to third party as a whole or partly, without the written consent of JQL Electronic Inc.