

1		2		3		4		5		6	
Document No.	QR4-700-T-003	REV.	A/0	REV.	DESCRIPTION	REVISOR	DATE	APPROVED			
				0		ZC.Wu	09.25.2017	David			

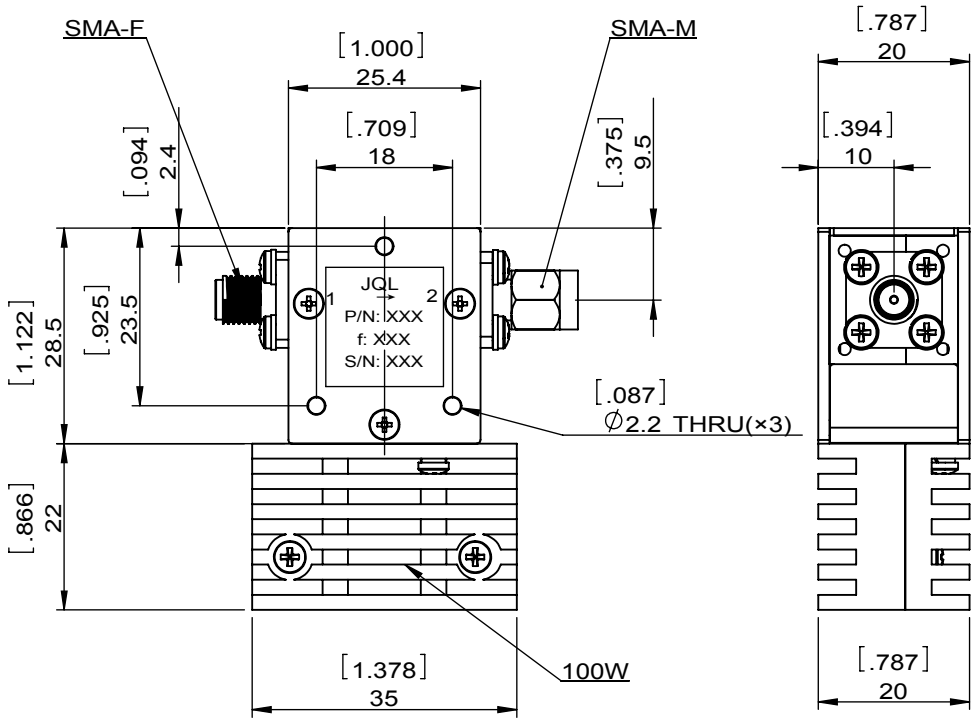
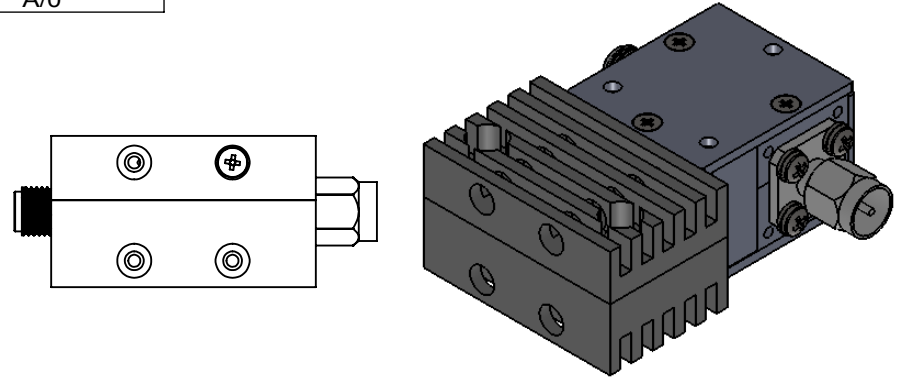

SPECIFICATIONS	
Part's Number	JIC2900T3200SFSM25R
Frequency(GHz)	2.900~3.200
Direction	-
Insertion Loss(dB)MAX	0.40
Isolation(dB)MIN	20.0
Return Loss(dB)MIN	19.0
3rd IMD(dBc)MAX	-
Power FWD/REV/PK(Watt)	100/25/-
Operating Temperature(°C)	-30~+60
Storage Temperature(°C)	-
2nd/3rd Harmonic(dBc)	-
Termination/Attenuator(Watt/dB)	100/-
Tab(W×LG×THK)(mm[Inch])	-
Additional Notes	-

JQL JQL Electronic Inc

MATERIAL: STEEL	DWG NO: JIC2900T3200SFSM25R			
SURFACE TREATMENT: NICKEL PLATING	DWG BY:	ZC.Wu	09.25.2017	SCALE
	CHK'D BY:			
DESCRIPTION: COAXIAL ISOLATOR	APPV'D BY:			1:1
	Unit: mm[inch]	Tolerance: Liner: ±0.25 Anguar: ±0.5°	The First:	A4

This document is the property of JQL Electronic Inc. It cannot be copied, duplicated, used for manufacturing purposes or communicated to third party as a whole or partly, without the written consent of JQL Electronic Inc.