

1	2
Document No.	QR4-700-T-003
REV.	A/0

4	5	6		
REV.	DESCRIPTION	REVISOR	DATE	APPROVED
0		LJ.Zhang	05.30.2014	David

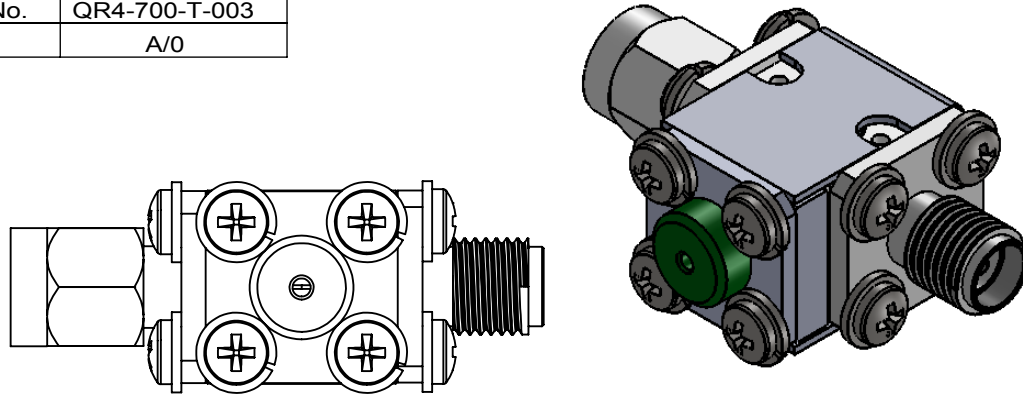

SPECIFICATIONS	
Part's Number	JIC4100T4700SMSF0
Frequency(GHz)	4.100~4.700
Direction	-
Insertion Loss(dB)MAX	0.40
Isolation(dB)MIN	20.0
Return Loss(dB)MIN	20.0
3rd IMD(dBc)MAX	-
Power FWD/REV/PK(Watt)	1/1/-
Operating Temperature(°C)	-30~+70
Storage Temperature(°C)	-40~+85
2nd/3rd Harmonic(dBc)	-25
Termination/Attenuator(Watt/dB)	1
Tab(W×LG×THK)(mm[Inch])	-
Additional Notes	-

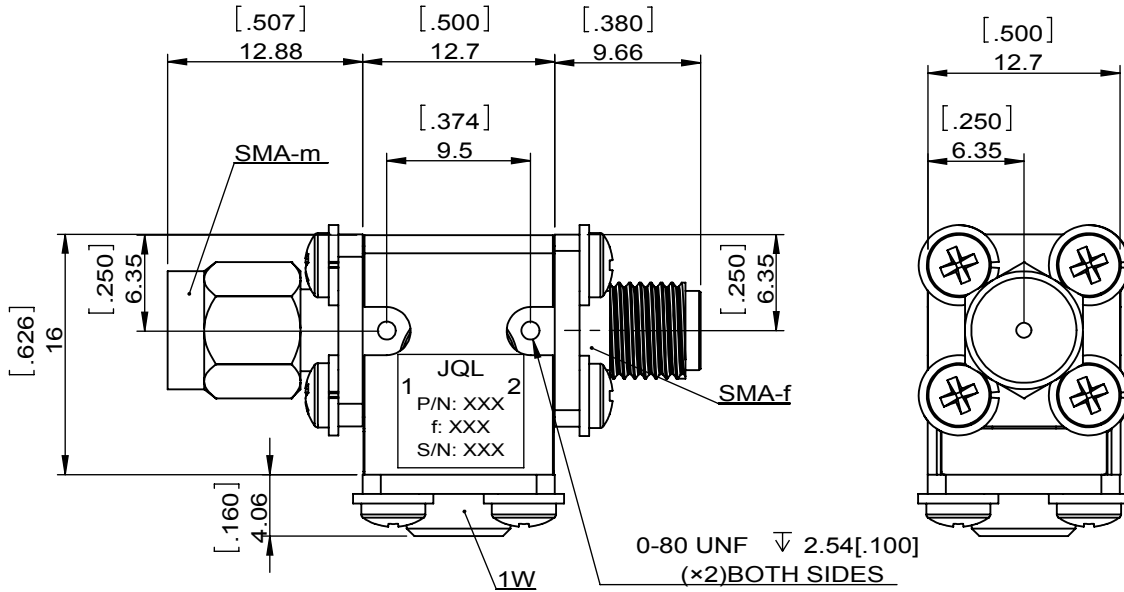

JQL JQL Electronic Inc				
MATERIAL: STEEL		DWG NO: JIC4100T4700SMSF0		
SURFACE TREATMENT: NICKEL PLATING		DWG BY:	LJ.Zhang	05.30.2014
DESCRIPTION: COAXIAL ISOLATOR		CHK'D BY:		
		APPV'D BY:		
Unit:	Tolerance:	The First:		2:1
mm[inch]	Liner: ±0.25 Anguar: ±0.5°			A4



This document is the property of JQL Electronic Inc. It cannot be copied, duplicated, used for manufacturing purposes or communicated to third party as a whole or partly, without the written consent of JQL Electronic Inc.