

Stock Number  
402010259

REV.	DESCRIPTION	REVISOR	DATE	APPROVE
0		CG	09.25.10	CH

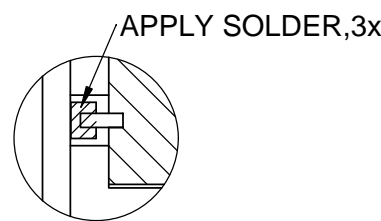
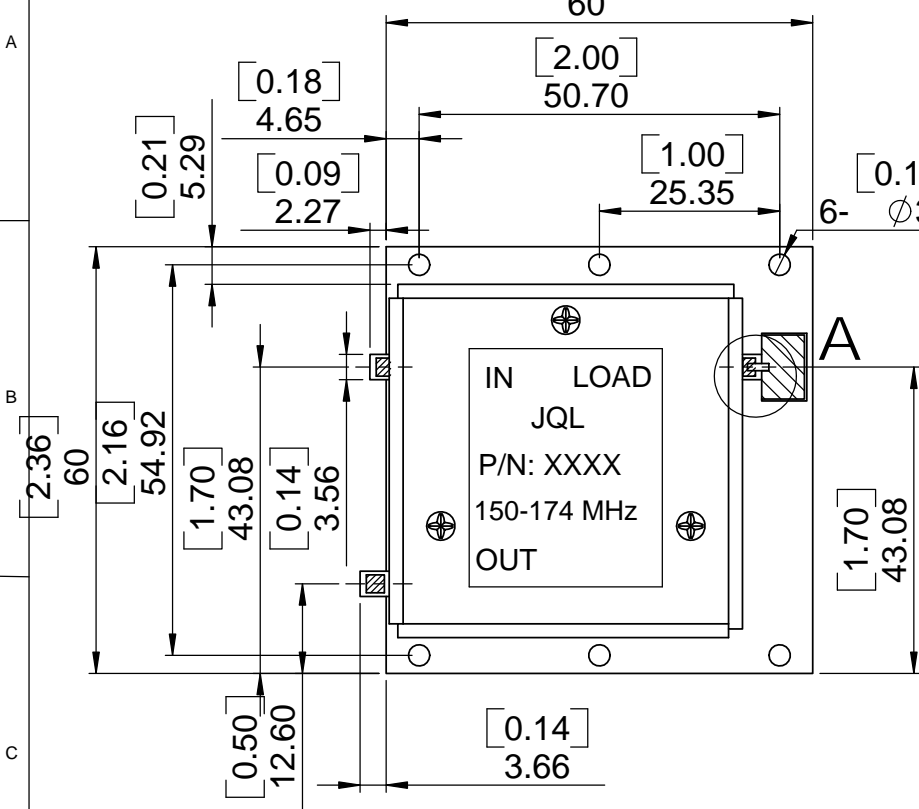

Local View A  
Scale 2:1

**SPECIFICATION**

Part's Number: JID0137T0156P10  
Frequency: 0.137-0.156GHz

Direction: CW  
Insertion Loss: 0.70dB Max  
Isolation: 18.0dB Min  
Return Loss: 18.0dB Min  
Power : 250W PEAK  
150W AVG  
100W REV

Termination: 100W  
Temperature: -25 °C~+75 °C



This document is the property of JQL Electronic Inc.  
It cannot be copied, duplicated, used for manufacturing purposes  
or communicated to third party as a whole or partly,  
without the written consent of JQL Electronic Inc.

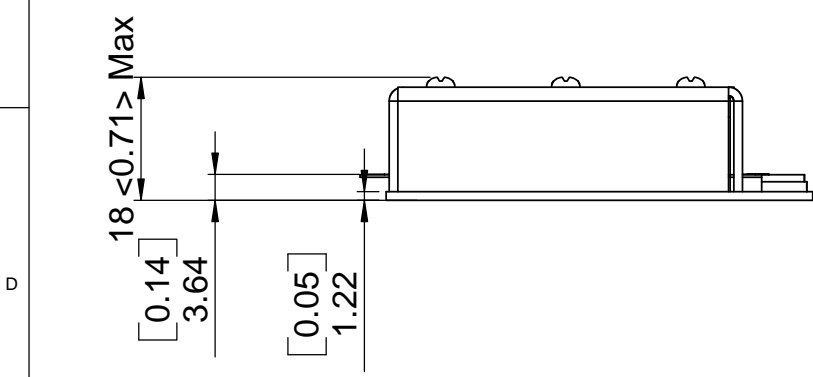

<b>JQL</b> JQL Electronic Inc		500 Lake Cook Road, Suite 350 Deerfield, IL 60015, USA		Tel : 1(888)236-9828 Fax: 1(630)823-2902	
MATERIAL: <b>STEEL</b>	DWG NO. <b>JID0137T0156P10</b>				
SURFACE TREATMENT: <b>Nickel Plating or Silver Plating</b>	NAME <b>CG</b>		DATE <b>09.25.10</b>		SCALE: <b>1:1</b>
DESCRIPTION: <b>Drop-In Circulator</b>	DWG BY:	<b>CG</b>	<b>09.25.10</b>	Type Of Projection 	
	CHK'D BY:	<b>FW</b>	<b>09.25.10</b>		
APPVD BY:	<b>CH</b>	<b>09.25.10</b>			
Unit: mm	TOLERANCE: Liner: ±0.127mm Angular: ±0.5°				<b>A4</b>

WEIGHT:

SHEET 1 OF 1