

1		2		3		4		5		6	
Document No.	QR4-700-T-003					REV.	DESCRIPTION	REVISOR	DATE	APPROVED	
REV.	A/0					0		ZC.Wu	06.03.2015	David	

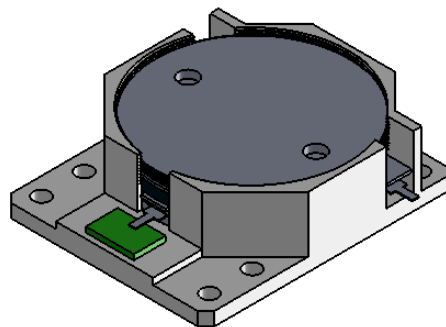

SPECIFICATIONS	
Part's Number	JID0420T0450KM10
Frequency(GHz)	0.420~0.450
Direction	CW
Insertion Loss(dB)MAX	0.3
Isolation(dB)MIN	21.0
Return Loss(dB)MIN	20.0
3rd IMD(dBc)MAX	-
Power FWD/REV/PK(Watt)	150/100/-
Operating Temperature(°C)	-30~+70
Storage Temperature(°C)	-
2nd/3rd Harmonic(dBc)	-
Termination/Attenuator(Watt/dB)	100
Tab(W×LG×THK)(mm[Inch])	1.30[0.051]x3[0.118]x0.2[0.008]
Additional Notes	-

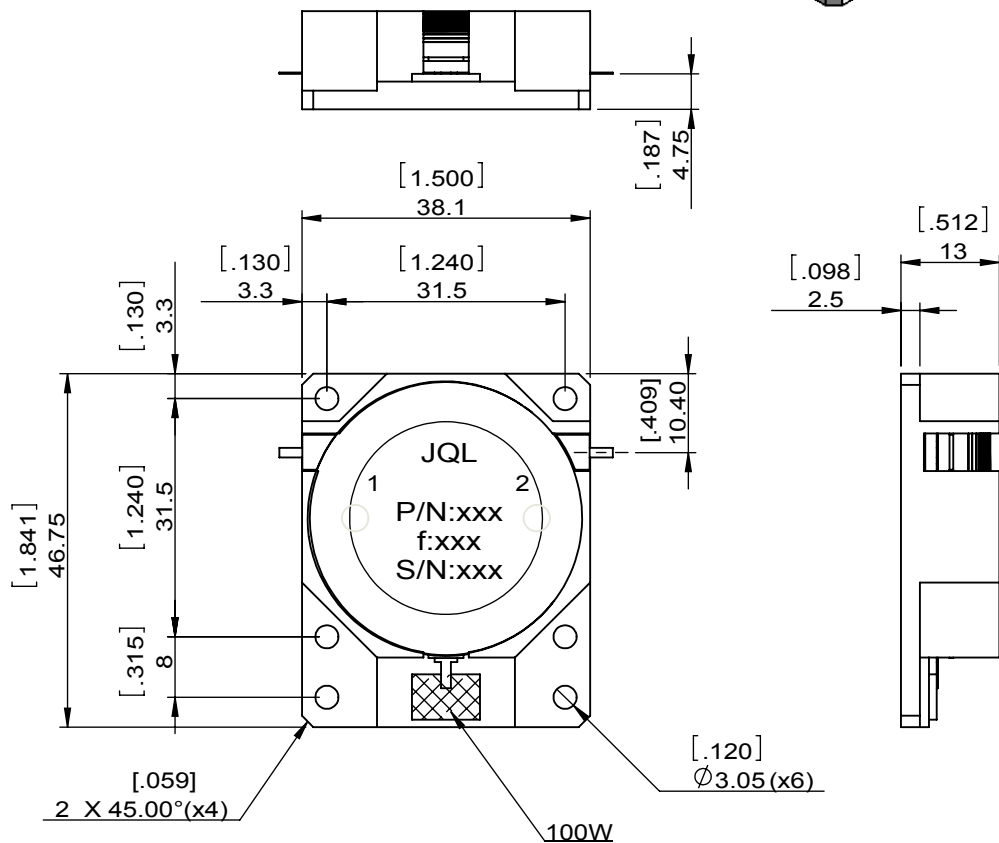

JQL JQL Electronic Inc				
MATERIAL: STEEL		DWG NO: JID0420T0450KM10		
SURFACE TREATMENT: NICKEL PLATING		DWG BY:	ZC.Wu	06.03.2015
DESCRIPTION: DROP-IN ISOLATOR		CHK'D BY:		SCALE
		APPV'D BY:		1:1
		Unit:	Tolerance:	The First:
		mm[inch]	Liner: ±0.25	
			Anguar: ±0.5°	A4



This document is the property of JQL Electronic Inc. It cannot be copied, duplicated, used for manufacturing purposes or communicated to third party as a whole or partly, without the written consent of JQL Electronic Inc.