

1	2
Document No.	QR4-700-T-003
REV.	A/0

4	5	6		
REV.	DESCRIPTION	REVISOR	DATE	APPROVED
0		M.Hao	08.14.2013	David

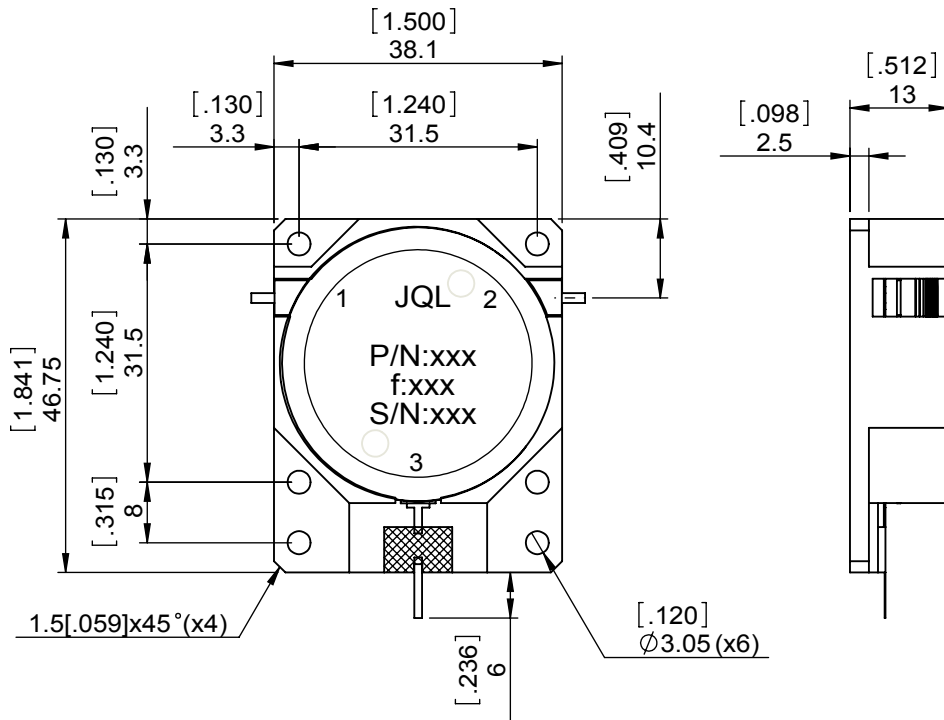
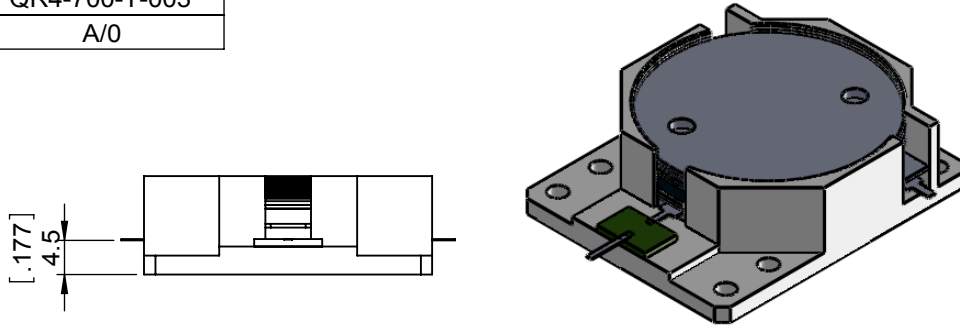

SPECIFICATIONS	
Part's Number	JID0440T0510KM10A3
Frequency(GHz)	0.440~0.510
Direction	CW
Insertion Loss(dB)MAX	0.40
Isolation(dB)MIN	20.0
Return Loss(dB)MIN	20.0
3rd IMD(dBc)MAX	-
Power FWD/REV/PK(Watt)	100/100/-
Operating Temperature(°C)	-20~+85
Storage Temperature(°C)	-
2nd/3rd Harmonic(dBc)	-
Termination/Attenuator(Watt/dB)	100/30
Tab(W×LG×THK)(mm[Inch])	1.30[0.051]x3[0.118]x0.2[0.008]
Additional Notes	-

**JQL** JQL Electronic Inc 500 Lake Cook Road, Suite 350 Deerfield, IL 60015, USA Tel: 1(888)236-9828 Fax: 1(888)823-2902

<b>MATERIAL:</b> STEEL	<b>DWG NO:</b> JID0440T0510KM10A3			
<b>SURFACE TREATMENT:</b> NICKEL PLATING	DWG BY:	M.Hao	08.14.2013	SACLE
	CHK'D BY:			
<b>DESCRIPTION:</b> DROP IN ISOLATORT	APPV'D BY:			1:1
	Unit: mm[inch]	Tolerance: Liner: ±0.25 Anguar: ±0.5°	The First:	A4



This document is the property of JQL Electronic Inc. It cannot be copied, duplicated, used for manufacturing purposes or communicated to third party as a whole or partly, without the written consent of JQL Electronic Inc.