

1		2		3		4		5		6	
Document No.	QR4-700-T-003	REV.	A/0	REV.	DESCRIPTION	REVISOR	DATE	APPROVED			
				0		ZC.Wu	11.09.2015	David			

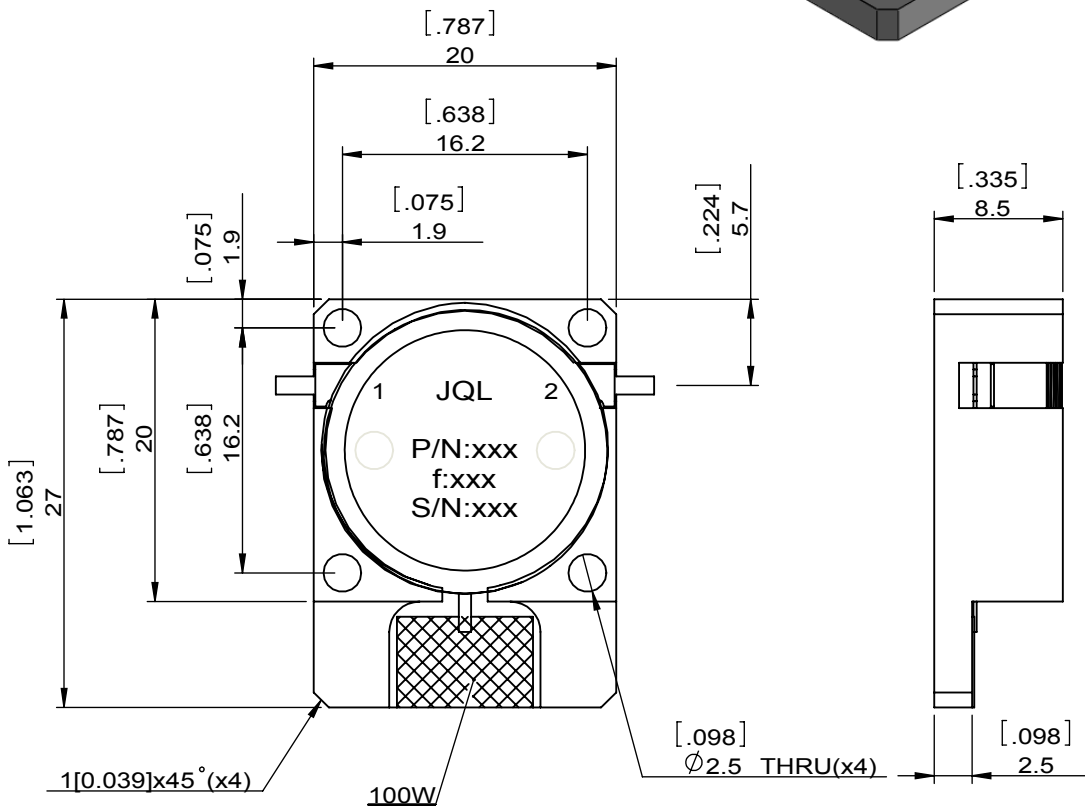

SPECIFICATIONS	
Part's Number	JID0884T0894AM10
Frequency(GHz)	0.884~0.894
Direction	CW
Insertion Loss(dB)MAX	0.35
Isolation(dB)MIN	20
Return Loss(dB)MIN	20.0
3rd IMD(dBc)MAX	-
Power FWD/REV/PK(Watt)	100/100
Operating Temperature(°C)	-20~+80
Storage Temperature(°C)	-
2nd/3rd Harmonic(dBc)	-
Termination/Attenuator(Watt/dB)	-
Tab(W×LG×THK)(mm[Inch])	1.2[0.047]x2.5[0.098]x0.2[0.008]
Additional Notes	-

JQL JQL Electronic Inc				
MATERIAL: STEEL		DWG NO: JID0884T0894AM10		
SURFACE TREATMENT: NICKEL PLATING		DWG BY:	ZC.Wu	11.09.2015
DESCRIPTION: DROP IN ISOLATOR		CHK'D BY:		SCALE
		APPV'D BY:		2:1
Unit:	Tolerance:	The First:		A4
mm[inch]	Liner: ±0.25 Anguar: ±0.5°			

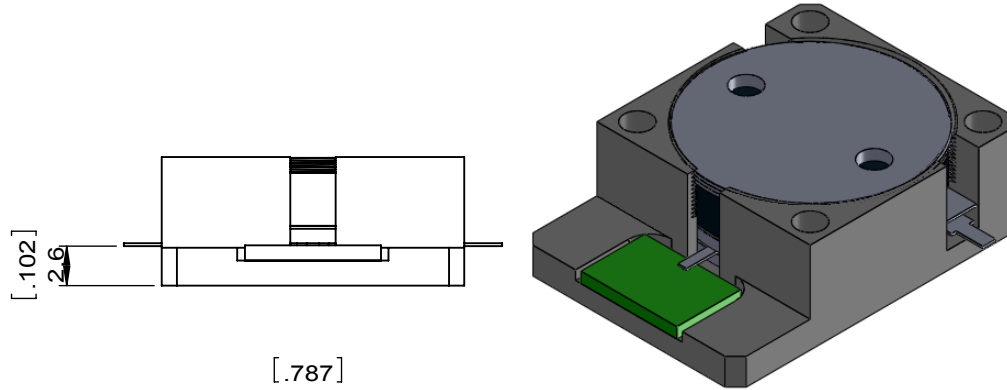

This document is the property of JQL Electronic Inc. It cannot be copied, duplicated, used for manufacturing purposes or communicated to third party as a whole or partly, without the written consent of JQL Electronic Inc.